

Operation Manual Syncore® SPE Accessories



093209 en

Table of contents

1	About this manual	4
1.1	Reference documents	4
1.2	Trademarks	4
1.3	Abbreviations	4
2	Safety.	5
2.1	User qualification	5
2.2	Proper use	5
2.3	Improper use	5
2.4	Warning notices used in this manual	5
2.5	Safety measures	6
2.6	General safety rules	6
3	Scope of delivery and technical data	7
3.1	SPE Basic accessory	7
3.2	SPE Advanced accessory	8
3.3	Technical data overview	9
4	Commissioning	10
4.1	Commissioning the SPE Basic accessory	10
4.2	Commissioning the SPE Advanced accessory	11
4.3	Functional test.	13
4.3.1	SPE Basic setup	13
4.3.2	SPE Advanced setup	14
4.3.3	Remedy in case of a leak	14
5	Operation	15
5.1	Operating the SPE Basic accessory	15
5.2	Operation of the SPE Advanced accessory	16
6	Maintenance.	17
6.1	Maintenance on the SPE Basic accessory.	17
6.2	Maintenance on the SPE Advanced accessory	17
7	Spare parts.	18
7.1	SPE Basic accessory	18
7.2	SPE Advanced accessory	19

Read this manual carefully before installing and running your system and note the safety precautions in chapter 2 in particular. Store the manual in the immediate vicinity of the instrument, so that it can be consulted at any time.

No technical modifications may be made to the instrument without the prior written agreement of Buchi. Unauthorized modifications may affect the system safety or result in accidents.

This manual is copyright. Information from it may not be reproduced, distributed, or used for competitive purposes, nor made available to third parties. The manufacture of any component with the aid of this manual without prior written agreement is also prohibited.

The English manual is the original language version and serves as basis for all translations into other languages. **If you need another language version of this manual, you can download available versions at www.buchi.com.**

1 About this manual

This manual describes two accessories used for sample work-up based on solid phase extraction (SPE) and/or filtration in conjunction with the Syncore Polyvap, Analyst or Reactor. It provides all information required for their safe operation and to maintain them in good working order. It is addressed in particular to laboratory personnel and operators.

NOTE

The symbols pertaining to safety (WARNINGS and ATTENTIONS) are explained in chapter 2.

1.1 Reference documents

For information on the Syncore, Vacuum Controller V-850/855 and the Vacuum Pump V-700/710, please refer to the corresponding manuals available in English, German, French, Spanish and Italian:

- Syncore Platform, Operation Manual numbers 93007 - 93011
- Syncore Accessories, Operation Manual numbers 93012 - 93016
- Vacuum Controller, Operating Manual numbers 93081 - 93085
- Vacuum Pump, Operating Manual numbers 93090 - 93094

1.2 Trademarks

The following product names and any registered and unregistered trademarks mentioned in this manual are used for identification purposes only and remain the exclusive property of their respective owners:

- Syncore® is a registered trademark of Büchi Labortechnik AG

1.3 Abbreviations

<i>ETFE:</i>	Ethylene tetrafluoroethylene
<i>FEP:</i>	Combination of tetrafluoroethylene and hexafluoropropylene
<i>PEEK:</i>	Polyetheretherketone
<i>PFA:</i>	Perfluoroalkoxyethylene
<i>POM:</i>	Polyoxymethylene
<i>PTFE:</i>	Polytetrafluoroethylene
<i>SPE:</i>	Solid phase extraction
$\Delta p:$	Pressure difference
$\Delta T:$	Temperature difference

2 Safety

This chapter highlights the safety concept of the SPE accessories and contains general rules of behavior and warnings from hazards concerning the use of the products.

The safety of users and personnel can only be ensured if these safety instructions and the safety-related warnings in the individual chapters are strictly observed and followed; therefore, the manual must always be available to all persons performing the tasks described herein.

2.1 User qualification

The accessories may only be used by laboratory personnel or other persons who on account of training or professional experience have an overview of the dangers which can occur when operating the instrument.

Personnel without this training or persons who are currently being trained require careful supervision. The present Operation Manual serves as a basis for training.

2.2 Proper use

The accessories have been designed and built for laboratory use only. They serve for activities associated with parallel sample work-up in conjunction with the Syncore Polyvap/Analyst such as filtration and solid phase extraction of multiple samples by means of vacuum, with or without regulation by a vacuum controller. Typically vacuum is applied using a PTFE diaphragm vacuum pump.

2.3 Improper use

Applications beyond those described above are improper. Furthermore, applications which do not comply with the technical data are also considered improper. The operator bears the sole risk for any damages caused by such improper use.

2.4 Warning notices used in this manual



WARNING

Generally, the triangular warning symbol indicates the possibility of personal injury or even loss of life if the instructions are not followed.



WARNING

Hot surface.



ATTENTION

With the “Read this” symbol, ATTENTION indicates the possibility of equipment damage, malfunctions or incorrect process results if the instructions are not followed.

NOTE

Useful tips for the optimum operation of the instrument.

2.5 Safety measures



Always wear personal protective equipment such as protective goggles, protective clothing and gloves when working with the instrument.



2.6 General safety rules

Responsibility of the operator

The head of laboratory is responsible for training his personnel.

The operator shall inform the manufacturer without delay of any safety-related incidents which might occur during the operation of the instrument. Legal regulations, such as local, state and federal laws applying to the instrument must be strictly followed.

Duty of maintenance and care

The operator is responsible for ensuring that the instrument is only operated in proper manner and that maintenance, service, and repairs are performed with care, on schedule and by authorized personnel only.

Spare parts to be used

Use only recommended consumables and spare parts for maintenance to ensure continued optimum system performance and reliability. Any modifications to the spare parts used are only allowed with the prior written permission of the manufacturer.

Modifications

Modifications to the instrument are only permitted after prior consultation with and written approval obtained from the manufacturer. Modifications and upgrades should only be carried out by an authorized Buchi technical engineer. The manufacturer reserves the right to decline any claim resulting from unauthorized modifications.

3 Scope of delivery and technical data

This chapter introduces the reader to the main components of the SPE accessories. There are two different accessories available, the SPE Basic accessory for direct elution into the Syncore's collecting vessels, and the SPE Advanced accessory including separation of liquids used for conditioning, enrichment and washing to a waste vessel prior to the elution step. Both accessories are available as MODULE to upgrade an existing Syncore vacuum cover, or as COVER which includes a complete vacuum cover SPE setup.

NOTE

The SPE Basic setup is compatible with the standard Inert Gas Module of the Syncore. Therefore, an upgrade of the Inert Gas Module to the corresponding SPE Basic Module is possible using the spare parts listed in Table 10.1.

3.1 SPE Basic accessory

The SPE Basic accessory is a tool for direct elution of a sample through Luer-tipped cartridges or filter discs into the Syncore's collecting vessels. The speed of the filtration process can easily be regulated by flow control valves. The liquid is lead through flanged FEP tubes into the collecting vessel of the Syncore for subsequent evaporation.

The SPE Basic accessory is available for the Syncore formats 12 and 24, other formats like 4, 6 or 48 are available on request. The accessory comprises a coated aluminum plate with flow control valves and flange tubes according to the number of ports.

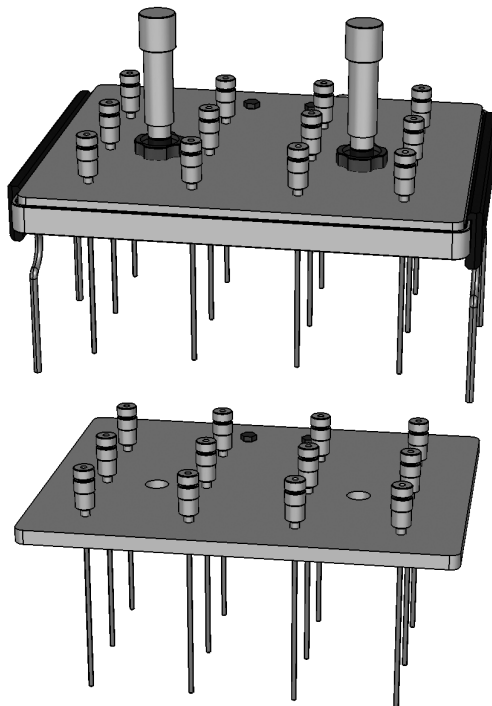

Table 3-1: SPE Basic accessory (cover at top and module at bottom)

Number of ports	Module	Cover
Rack format 4	*	*
Rack format 6	*	*
Rack format 12	51440	51438
Rack format 24	51463	51439
Rack format 48	*	*

* available on request

3.2 SPE Advanced accessory

In contrast to the SPE Basic accessory, the SPE Advanced accessory allows for liquid separation into either a waste vessel or a collecting vessel after passing through a SPE cartridge. It therefore consists of three-way stop-cocks instead of flow control valves and an additional waste vessel. The Advanced accessory is designed for typical SPE work-up including conditioning, enrichment with the sample, washing, elution and evaporation.

NOTE

The outlet of the waste vessel can be combined with the temperature probe inlet of the Syncore type S condenser. All SPE Cover instructions in this manual refer to this type of condenser. Other configurations are possible but require an extra vacuum connection for the waste vessel.

The SPE Advanced accessory is available in the formats 6 and 12. Higher capacity formats like 24 or 48 are not possible due to spatial constraints involving the three-way stop-cock. This accessory comprises a vacuum cover with a coated aluminum plate, three-way stop-cocks, tubes according to the number of ports and a waste vessel.

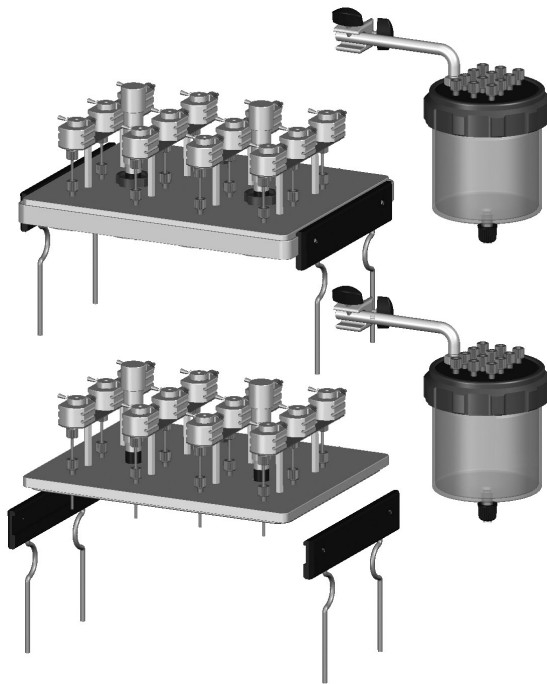

Table 3-2: SPE Advanced accessory (cover at top and module at bottom, tubes to waste are not shown)

Number of ports	Module	Cover
Rack format 6	11055465	11055466
Rack format 12	51164	51448

* available on request

3.3 Technical data overview

Table 3-3: Technical data SPE Basic Accessory

Dimensions (W x H x D)	30 x 5 x 24 cm (without tubes)
Weight	5 kg
Material used	Base plate: Aluminium ematal coated Valve: PEEK O-ring: Fluororubber Tube: FEP

Table 3-4: Technical data SPE Advanced Accessory

Dimensions (W x H x D)	30 x 28 x 24 cm (without tubes)
Weight	6.2 kg
Material used	Base plate: Aluminium ematal coated SPE stop-cock: PTFE and PFA Fittings: POM Ferrules: ETFE Tube: FEP Waste manifold: POM Waste vessel: Borosilicate glass

4 Commissioning

This chapter describes the installation of the SPE accessories and the measures for the initial start-up.

NOTE:

Inspect the accessories for damages during unpacking. If necessary, prepare a status report immediately to inform the postal company, railway company or transport company. Keep the original packaging for future transport.

4.1 Commissioning the SPE Basic accessory

To install the sealing of the SPE Basic accessory proceed as follows:

1. Remove the glass plate ① of the Syncore vacuum cover.
2. Put the seal ② back in place.

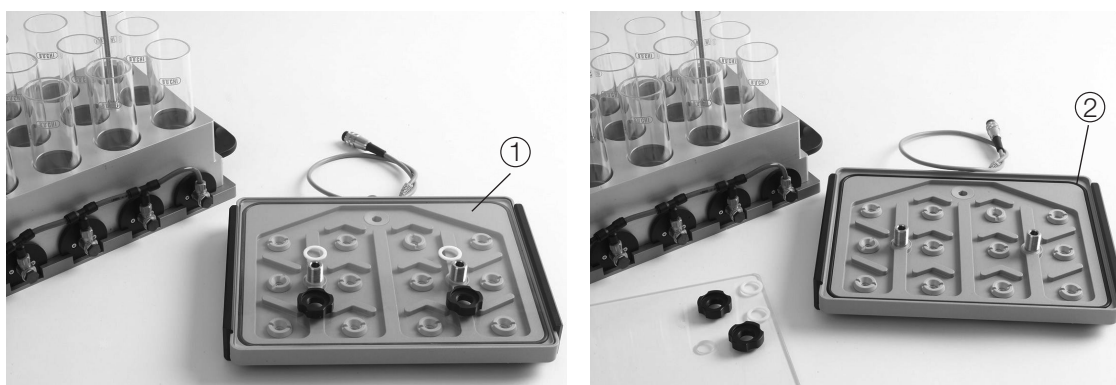

3. Put the aluminium plate ③ onto the cover, install the washers ④ between the metal plate and the lock nuts and fix the assembly properly with the corresponding Syncore tool ⑤.

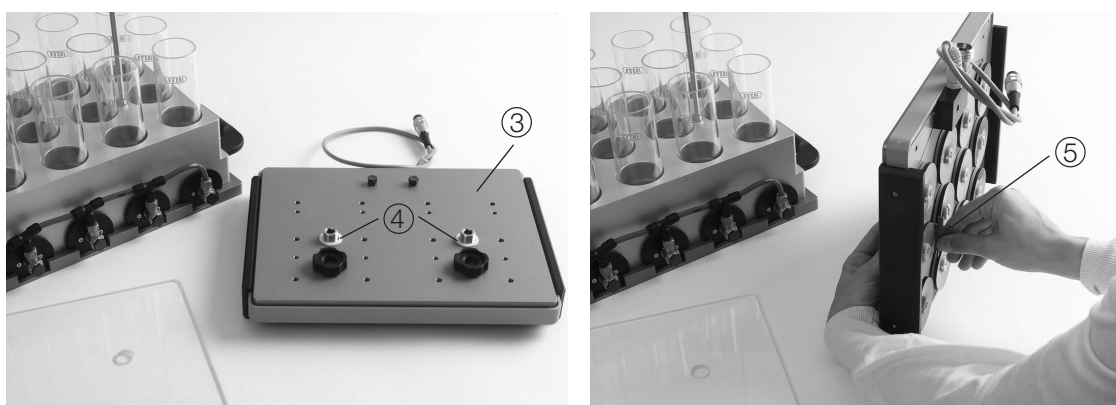

4. Put the cover onto the Syncore rack and transfer the flanged tube ⑥ through the vapor duct of each port. Cut the length of the tube if necessary. Screw the flow control valves ⑦ hand tight into the 12 ports.

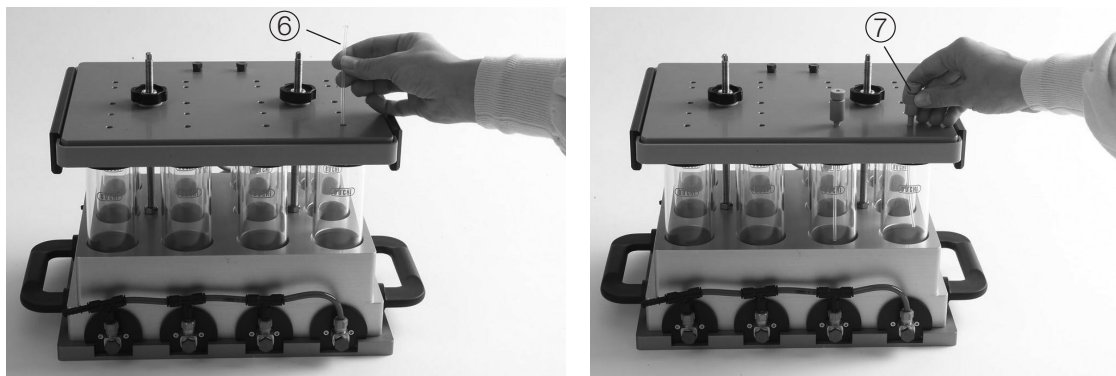

5. Close the flow control valve and check the vacuum tightness. The system is tight when it has a leak rate < 8 mbar/min. See also section 4.3.



WARNING

It is strongly recommended to place the instrument in a fume hood when working with hazardous chemicals.

4.2 Commissioning the SPE Advanced accessory

To install and seal the SPE cover proceed as follows:

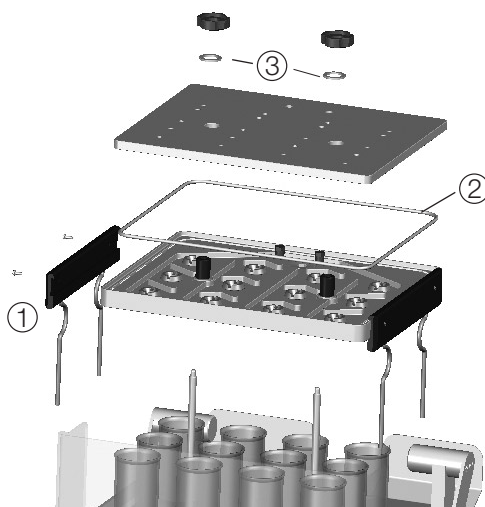

1. Exchange the sidebars of the standard vacuum cover with the sidebars with feet ①.
2. Remove the glass plate from the standard vacuum cover as described in section 4.1.
3. Place the seal ② back into the corresponding groove.
4. Fix the metal plate as described in section 4.1. Do not forget the washers ③.
5. Now place the whole assembly onto the Syncore rack.

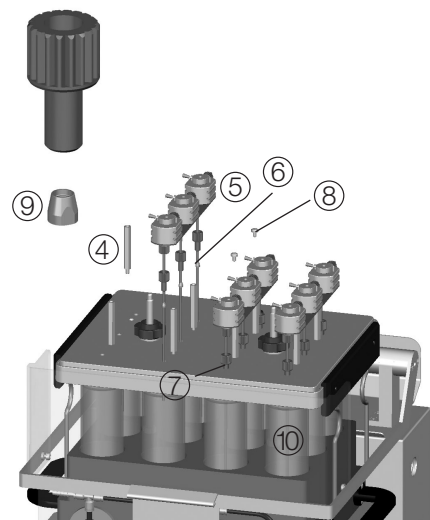

6. Screw the SPE support rod ④ onto the metal plate.
7. Take the assembly ⑤, plunge the three tubes ⑥ through the corresponding holes and through the vapor duct of the vacuum cover.
8. First, fix the green fittings ⑦ onto the metal plate and then screw the support ⑧ onto the support rods. Make sure that the cone of the ferrule ⑨ points towards the fitting.
9. Cut the length of the tubes ⑩ inserted into the collecting vessel if necessary using the cutter 019830.

10. Install the waste vessel ① on top of the rod next to the Syncore platform or on a separate stand close to the type S condenser ②. Connect the outlet ③ of the vessel with the temperature probe joint ④ of the condenser using the tube ⑤. Make sure that the seals ⑥ are oriented correctly as depicted in the scheme.

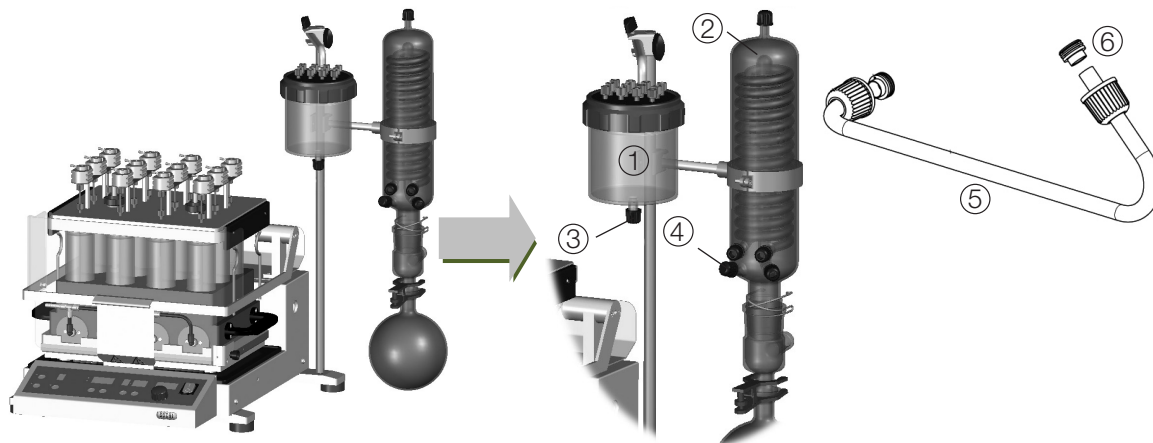

ATTENTION

The liquids are not trapped in the waste vessel but rather transferred into the receiving flask of the type S condenser. Any installations deviating from the one shown below would require an additional vacuum source and solvent trap (Wouff bottle) to prevent contamination of the vacuum source.

11. Connect the FEP tubes of the three-way stop-cocks with the manifold of the waste vessel. Make sure that the first row ⑦ of the cover corresponds to the first row ⑦ of the waste (indicated by the dotted line), that the middle row of the cover corresponds to the middle row of the waste, and that the third row of the cover ⑧ corresponds to the third row of the waste ⑧ (indicated by the other line). The length of the tubes is adjusted accordingly. The recommended length of the tube entering the waste vessel is approximately 3 cm. This facilitates the loading of the cartridge as the flow rate of each port can easily be observed. Use the ferrules ⑨ and fittings ⑩ to fix the tubes on the waste manifold. Use 2 x 2 clips 51458 to bundle the tubes.

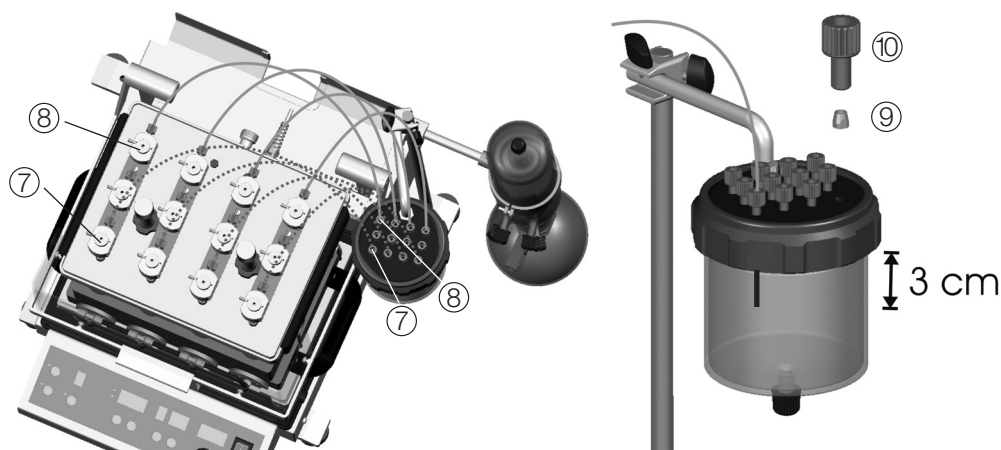

12. Fix the cover properly on the rack using the SPE lock nuts (11). Turn all stop-cocks to the middle position and check the vacuum tightness. The system is tight when it has a leak rate < 10 mbar/min. See also section 4.3.3. The instrument is now ready to be equipped with the SPE cartridges.

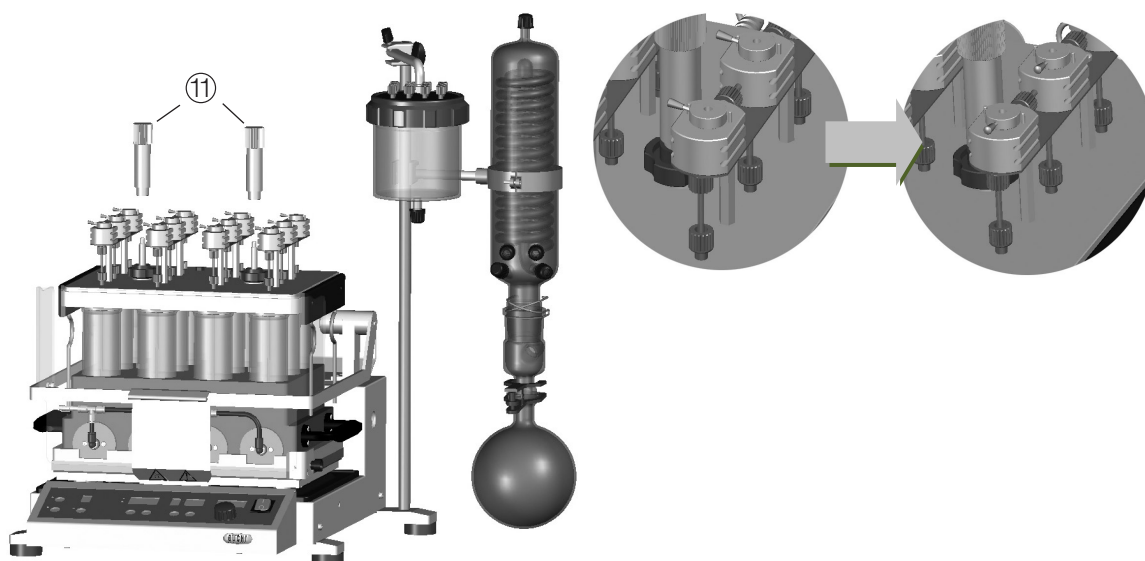

WARNING

It is strongly recommended to place the instrument in a fume hood when working with hazardous chemicals.

4.3 Functional test

Once all of the described installation steps have been completed, proceed with the following functional test in order to correctly operate the instrument.

NOTE

The vacuum tightness test can only be carried out using a vacuum controller installed or a pressure measuring device (manometer) that has been installed between the pump and the Syncore.

4.3.1 SPE Basic setup

1. Close the flow control valve. Apply a vacuum of a preset value, e.g. 300 mbar. Stop the vacuum and measure the pressure increase Δp within 2 min. The system is tight when the leak rate does not exceed 10 mbar/min.
2. Equip all ports with a Luer-tipped cartridge or filter disc. Add 5 ml of ethanol into each cartridge. In the closed position, the liquid must not pass through the valve into the collecting vessel.
3. Apply a vacuum of approximately 800 mbar. Adjust the flow rate of each position by turning the valve slowly to the left.

4.3.2 SPE Advanced setup

1. Turn the stop-cock to the middle position. Apply vacuum to a preset value, e.g. 300 mbar. Stop the vacuum and measure the pressure increase Δp within 2 min. The system is tight when the leak rate does not exceed 10 mbar/min.
2. Equip all ports with a SPE cartridge. Add 5 ml ethanol into each cartridge. In the closed position, the liquid must not pass through the valve into the sample or waste vessel.
3. Apply a vacuum of approximately 800 mbar. Turn the stop-cock to the right position for passing the liquid into the waste vessel. Turning the stop-cock to the left transfers the liquid into the collecting vessel.

4.3.3 Remedy in case of a leak

1. Remove the SPE Cover and measure the leak rate of the original Syncore setup if possible. If the leak rate remains too high, proceed as follows:
 - a. Close the vacuum tube from the vacuum pump to the condenser and check the leak rate of the pump. In case of a leak consult the corresponding manual.
 - b. Close the vacuum tube side of the condenser with a blind plug and check the leak rate of the condenser assembly. In case of a leak check the seals of the vacuum tube and the GL 14 caps. Grease the glass joints if necessary. Check the seals of the joint on both sides of the ribbed vacuum tube connecting the vacuum cover and condenser.
 - c. Verify the quality of the collecting vessels. They must not be chipped.
 - d. Replace the big black EPDM O-ring in the vacuum cover and/or the small silicon seals around the rack rods which seal the glass plate.
 - e. Replace the sealing and washers of the vacuum cover.
2. If the leak rate is significantly lower when using the standard cover, then the leak originates from the SPE Cover. For the Basic setup proceed as follows:
 - a. Leaky flow control valves can be located by adding some solvent (e.g. ethanol) to the screw threaded connection of the metal plate located at the female Luer joint. Decreasing volumes upon application of vacuum indicate a leak. Replace the valve 051451. Use blank fittings (044301) to temporarily close the corresponding port(s).
3. For the Advanced accessory proceed as follows:
 - a. Make sure that all green fittings are screwed hand tight. Do not use the fitting removal tool 054400 as it may irreversibly damage the screw threads.
 - b. Check the tightness of the waste vessel by closing the GL 14 joint of the type S condenser with a blind cap. Replace the seals of the FEP tube and/or the seal of the waste vessel (040471).
 - c. Check the three-way stop-cocks by placing some solvent (e.g. ethanol) around the joint and onto the female Luer joint. Decreasing volumes upon application of vacuum indicate a leak. Replace the stop-cock 051150. Use blank fittings (044301) to temporarily close the corresponding port(s).



ATTENTION

Over tightening the green fittings on the three-way stop-cock may irreversibly damage the stop-cock. Only hand tighten the screw threaded fittings.



WARNING

Hot surface! The vacuum cover can be heated to up to 70°C. For more information see the Operation Manual for the Syncore Platform.

5 Operation

This chapter explains the operating elements and possible operating modes. It gives instructions on how to operate the SPE accessories properly and safely.

5.1 Operating the SPE Basic accessory

1. Turn the flow control valve to the right stop position to close the system.
2. Put the cartridge or filter disc onto the valve and apply vacuum (e.g. 800 mbar).

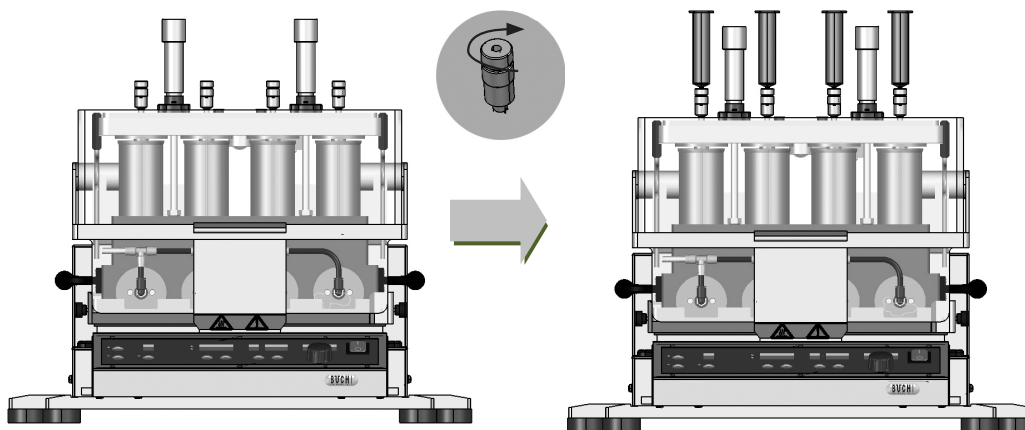

3. Load the cartridge.
4. Adjust the flow by slowly turning the flow control valve to the left. Hold the cartridge on the top to move the head of the flow control valve.

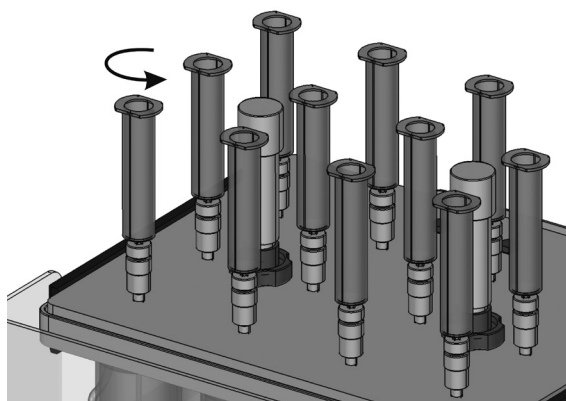

5.2 Operation of the SPE Advanced accessory

In general, for a typical SPE work-up there are five modes of operation: conditioning of the cartridge, enrichment of the sample, washing, elution and finally evaporation. The SPE cover allows all these tasks to be performed without interruption such as aeration of the system.

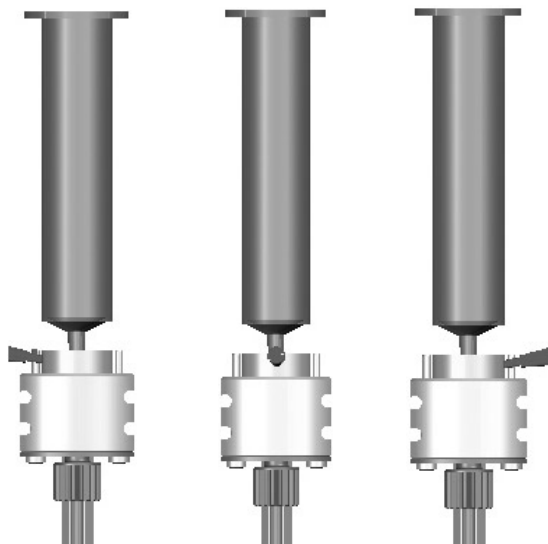

Description of the stop-cock positions:

1. Turn to the right position to transfer the liquid to the waste vessel. This typically applies to conditioning, enrichment and washing.
2. Turn to the middle position to stop the liquid transfer through the cartridge. Typically used for sample loading or evaporation.
3. Turn to the left position to elute the sample into the collecting vessel.

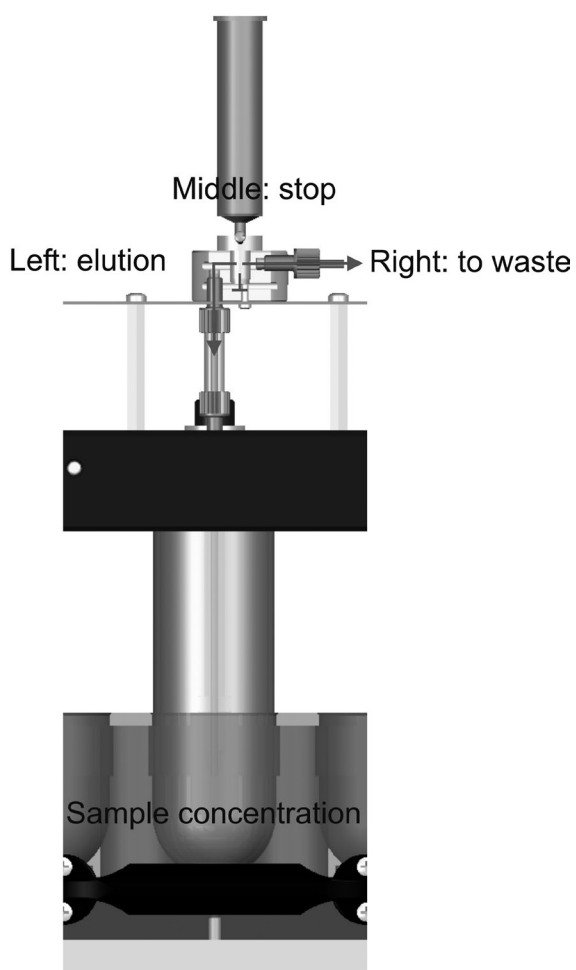

A typical SPE work-up involves the following steps:

1. Turn to the middle position to fill the cartridge.
2. Turn to the right position to condition the cartridge and to transfer the liquid into the waste vessel.
3. Turn to the middle position to load the sample.
4. Turn to the right position for enrichment. Check the flow rate by observing the amount of liquid passing into the waste vessel.
5. Remaining in the right position, wash the sample.
6. Turn to the left position for elution.
7. Turn to the middle position for evaporation.
8. Turn to the right and left position to clean the stop-cock and tubes with a suitable solvent.

6 Maintenance

This chapter provides instruction on all required maintenance to keep the instrument in good working conditions.

6.1 Maintenance on the SPE Basic accessory

The Basic accessory requires regular maintenance on the following spare parts:

1. Flow control valves: Unscrew the valves anti-clockwise.
2. Flanged tubes: Take off the SPE cover, remove the flow control valves and take out the flanged tubes from bottom to top.

6.2 Maintenance on the SPE Advanced accessory

The Advanced accessory requires regular maintenance on the following spare parts:

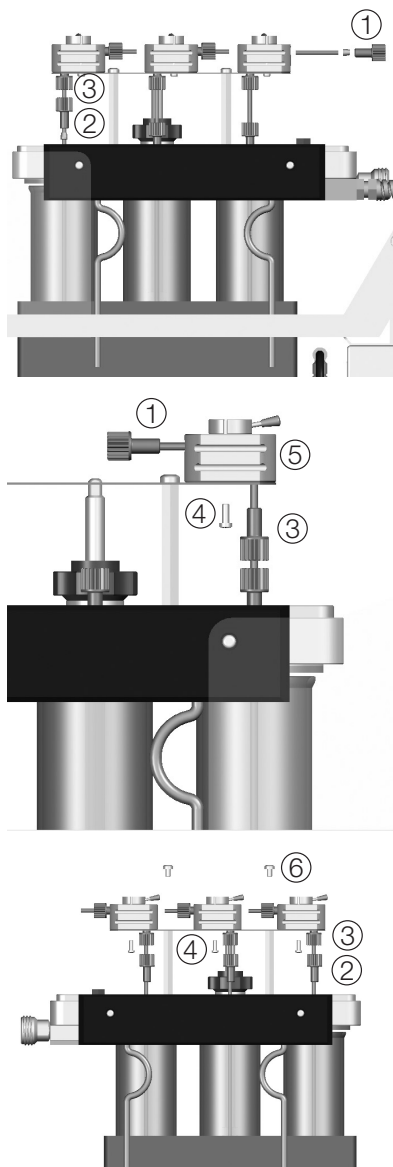

1. **Waste tubes:** Unscrew the green fittings ① anti-clockwise; use the fitting removal tool if necessary. Exchange the whole tube assembly 051455 of one row as the tubes are tailored to the positions of the ports on the cover and the waste manifold. Make sure that the cone of the ferrule points toward the fitting. Use the clips 051458 to bundle the tubes.
2. **Elution tubes:** Unscrew the green fittings ② and ③ anti-clockwise; use the fitting removal tool if necessary. Use the tube 044354 for exchange and cut the length with the tube cutter 019830, if necessary.
3. **Three-way stop-cock:** Unscrew both tube fittings ① and ③ first and then the screws ④ from the bottom using the enclosed angular Torx TX10 screwdriver. Make sure that the horizontal fitting ① of the new stop-cock points to the back.
ATTENTION: Only hand tighten the green tube fittings ① and ③. Never use the fitting removal tool to screw the fittings into the PTFE socket ⑤ as it may become irreversibly damaged. In addition, make sure that the cone of the ferrule points toward the fitting and the tube end is flush with the ferrule.
4. **Stop-cock support:** First remove all three fittings ② in a row on the metal plate. Then unscrew the Torx screws ⑥ from the top. The whole assembly can now be removed, providing free access to the remaining screws ④ and fittings ③ at the bottom.

7 Spare parts

This chapter lists spare parts, accessories, and optional extras, including all of the relevant order information for ordering from Buchi. Always state the product designation and part number when ordering any spare parts.

Use only genuine Buchi consumables and spare parts for maintenance and repair to ensure optimum system performance and reliability. Prior written permission of the manufacturer should be obtained before any modifications are made to the spare parts used.

7.1 SPE Basic accessory

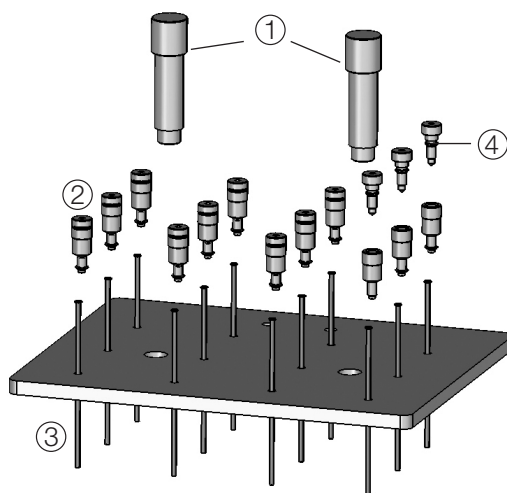
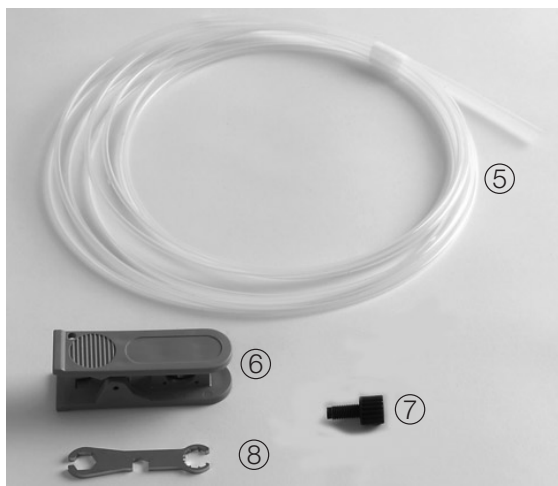
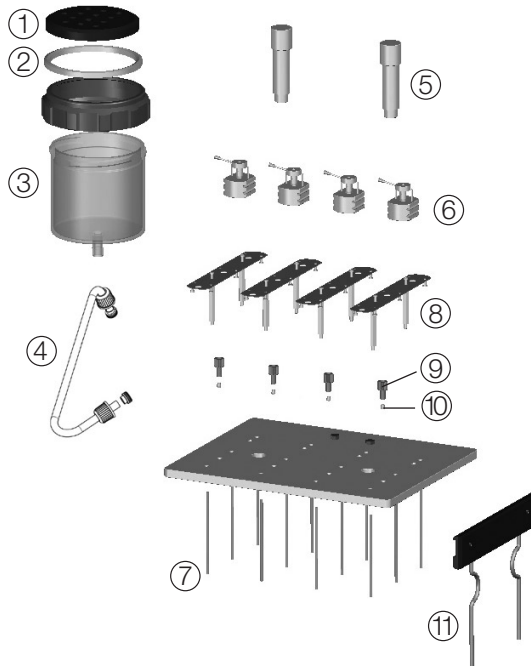

Table 10-1: SPE Basic accessory spare parts

Product	Order No.
① Set of 2 SPE lock nuts	51464
② Flow control valve	51129
Set of 12 flow control valves	51453
③ Set of 6 flanged FEP tubes	51459
④ Set of 12 FKM O-rings	51496
⑤ FEP tube (outer \varnothing 1/8", inner \varnothing 1/16", L = 5 m)	44354
⑥ Tube cutter	19830
⑦ Set of 10 blank fittings for vacant positions	54400
⑧ Turix wrench	44349
Fitting removal tool (not shown)	54400



7.2 SPE Advanced accessory

Table 10-2: SPE Advanced accessory spare parts

Number of ports	Module
① 12 port waste manifold	51445
① 6 port waste manifold	11055463
② Seal for waste vessel	40471
③ Waste vessel glass cylinder	51444
④ FEP tube waste --> condenser including GL 14 caps and seals	51467
⑤ Set of 2 SPE lock nuts	51464
⑥ Three-way stop-cock	51163
Set of 12 three-way stop-cocks	51457
4 x 3 waste tubes (length adjusted)	51455
Set of 4 tube clips (not shown)	51458
⑦ Set of 12 elution tubes	51492
⑧ Support for the three-way stop-cocks (12 ports)	51493
⑨ Set of 25 tube fittings 1/8' (green)	40956
⑩ Set of 25 ferrules 1/8'	40961
FEP tube (outer 1/8', inner 1/16', L = 5 m)	44354
Tube cutter (not shown)	19830
Fitting removal tool (not shown)	54400
⑪ Sidebar with feet	51465
Turix wrench	44349

BUCHI Affiliates:

Europe

Switzerland/Austria

BÜCHI Labortechnik AG
CH – 9230 Flawil
T +41 71 394 63 63
F +41 71 394 65 65
buchi@buchi.com
www.buchi.com

Benelux

BÜCHI Labortechnik GmbH
Branch Office Benelux
NL – 3342 GT Hendrik-Ido-Ambacht
T +31 78 684 94 29
F +31 78 684 94 30
benelux@buchi.com
www.buchi.be

France

BUCHI Sarl
FR – 94656 Rungis Cedex
T +33 1 56 70 62 50
F +33 1 46 86 00 31
france@buchi.com
www.buchi.fr

Germany

BÜCHI Labortechnik GmbH
DE – 45127 Essen
T +800 414 0 414 0 (Toll Free)
T +49 201 747 49 0
F +49 201 747 49 20
deutschland@buchi.com
www.buechigmbh.de

Italy

BUCHI Italia s.r.l.
IT – 20010 Cornaredo (MI)
T +39 02 824 50 11
F +39 02 575 12 855
italia@buchi.com
www.buchi.it

Russia

BUCHI Russia/CIS
Russia 127287 Moscow
T +7 495 36 36 495
F +7 495 98 10 520
russia@buchi.com
www.buchi.ru

United Kingdom

BUCHI UK Ltd.
GB – Oldham OL9 9QL
T +44 161 633 1000
F +44 161 633 1007
uk@buchi.com
www.buchi.co.uk

Germany

BÜCHI NIR-Online
DE – 69190 Walldorf
T +49 6227 73 26 60
F +49 6227 73 26 70
nir-online@buchi.com
www.nir-online.de

America

Brazil

BUCHI Brasil
BR – Valinhos SP 13271-200
T +55 19 3849 1201
F +55 19 3849 2907
brasil@buchi.com
www.buchi.com

USA/Canada

BUCHI Corporation
US – New Castle, DE 19720
T +1 877 692 8244 (Toll Free)
T +1 302 652 3000
F +1 302 652 8777
us-sales@buchi.com
www.mybuchi.com

Asia

China

BUCHI China
CN – 200052 Shanghai
T +86 21 6280 3366
F +86 21 5230 8821
china@buchi.com
www.buchi.com.cn

India

BUCHI India Private Ltd.
IN – Mumbai 400 055
T +91 22 667 75400
F +91 22 667 18986
india@buchi.com
www.buchi.in

Indonesia

PT. BUCHI Indonesia
ID – Tangerang 15321
T +62 21 537 62 16
F +62 21 537 62 17
indonesia@buchi.com
www.buchi.co.id

Japan

Nihon BUCHI K.K.
JP – Tokyo 110-0008
T +81 3 3821 4777
F +81 3 3821 4555
nihon@buchi.com
www.nihon-buchi.jp

Korea

BUCHI Korea Inc.
KR – Seoul 153-782
T +82 2 6718 7500
F +82 2 6718 7599
korea@buchi.com
www.buchi.kr

Malaysia

BUCHI Malaysia Sdn. Bhd.
MY – 47301 Petaling Jaya,
Selangor
T +60 3 7832 0310
F +60 3 7832 0309
malaysia@buchi.com
www.buchi.com

Singapore

BUCHI Singapore Pte. Ltd.
SG – Singapore 609919
T +65 6565 1175
F +65 6566 7047
singapore@buchi.com
www.buchi.com

Thailand

BUCHI (Thailand) Ltd.
TH – Bangkok 10600
T +66 2 862 08 51
F +66 2 862 08 54
thailand@buchi.com
www.buchi.co.th

BUCHI Support Centers:

South East Asia

BUCHI (Thailand) Ltd.
TH-Bangkok 10600
T +66 2 862 08 51
F +66 2 862 08 54
bacc@buchi.com
www.buchi.com

Middle East

BÜCHI Labortechnik AG
UAE – Dubai
T +971 4 313 2860
F +971 4 313 2861
middleeast@buchi.com
www.buchi.com

Latin America

BUCHI Latinoamérica Ltda.
BR – Valinhos SP 13271-200
T +55 19 3849 1201
F +55 19 3849 2907
latinoamerica@buchi.com
www.buchi.com

We are represented by more than 100 distribution partners worldwide.
Find your local representative at: www.buchi.com