

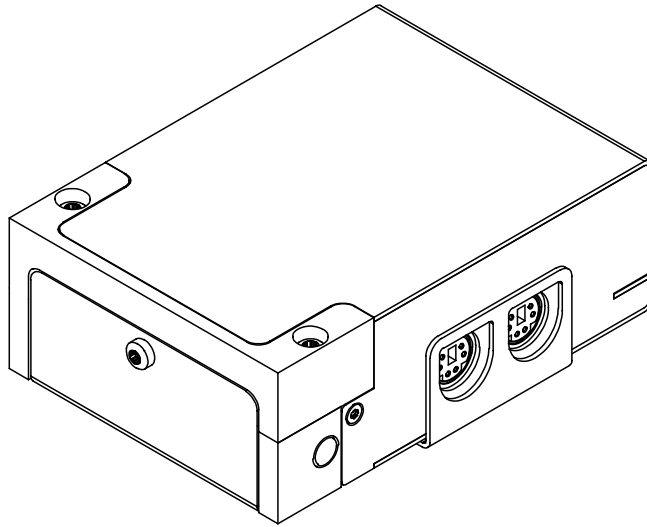

# Pure UV Detector C-107

## Operation Manual



## **Imprint**

Product Identification:  
Operation Manual (Original) Pure UV Detector C-107  
1159442

Publication date: 05.2023

Version A

BÜCHI Labortechnik AG  
Meierseggstrasse 40  
Postfach  
CH-9230 Flawil 1  
E-Mail: [quality@buchi.com](mailto:quality@buchi.com)

BUCHI reserves the right to make changes to the manual as deemed necessary in the light of experience, especially with respect to structure, illustrations and technical details.

This manual is copyrighted. Information from it may neither be reproduced, distributed, or used for competitive purposes, nor made available to third parties. The manufacture of any component with the aid of this manual without prior written agreement is also prohibited.

## Table of contents

<b>1</b>	<b>About this document.....</b>	<b>5</b>
1.1	Mark-ups and symbols.....	5
1.2	Trademarks.....	5
1.3	Connected instruments.....	5
<b>2</b>	<b>Safety.....</b>	<b>6</b>
2.1	Proper use.....	6
2.2	Use other than that intended.....	6
2.3	Staff qualification.....	6
2.4	Residual risks.....	7
2.4.1	Flow cell breakage.....	7
2.4.2	Leaking liquids.....	7
2.4.3	Aggressive solvents.....	7
2.4.4	UV radiation.....	7
2.4.5	Dangerous solvents.....	7
2.5	Warning symbols.....	7
2.6	Personal protective equipment.....	8
2.7	Modifications.....	8
<b>3</b>	<b>Product description.....</b>	<b>9</b>
3.1	Description of function.....	9
3.2	Front view.....	11
3.3	Rear view.....	11
3.4	Scope of delivery.....	11
3.5	Type plate.....	12
3.6	Technical data.....	12
3.6.1	Pure UV Detector C-107.....	12
3.6.2	Ambient conditions.....	12
3.6.3	Materials.....	13
3.6.4	Installation site.....	13
<b>4</b>	<b>Transport and storage.....</b>	<b>14</b>
4.1	Transport.....	14
4.2	Storage.....	14
<b>5</b>	<b>Installation.....</b>	<b>15</b>
5.1	Installing the instrument on Pure Chromatography C-900.....	15
5.2	Connecting the instrument within a chromatography system.....	15
<b>6</b>	<b>Operation.....</b>	<b>16</b>
<b>7</b>	<b>Cleaning and servicing.....</b>	<b>17</b>
7.1	Regular maintenance work.....	17
7.2	Cleaning the housing.....	17
7.3	Cleaning the flow cell.....	17
7.4	Replacing the flow cell.....	18
<b>8</b>	<b>Help with faults.....</b>	<b>21</b>
8.1	Faults, possible causes and solutions.....	21
8.2	Customer service.....	21

---

<b>9</b>	<b>Taking out of service and disposal.....</b>	<b>22</b>
9.1	Taking out of service.....	22
9.2	Disposal.....	22
9.3	Returning the instrument .....	22
<b>10</b>	<b>Appendix .....</b>	<b>23</b>
10.1	Spare parts and accessories .....	23
10.1.1	Spare parts .....	23
10.1.2	Accessories.....	23

# 1 About this document

This operation manual is applicable for all variants of the instrument. Read this operation manual before operating the instrument and follow the instructions to ensure safe and trouble-free operation.

Keep this operation manual for later use and pass it on to any subsequent user or owner.

BÜCHI Labortechnik AG accepts no liability for damage, faults and malfunctions resulting from not following this operation manual.

If you have any questions after reading this operation manual:

- ▶ Contact BÜCHI Labortechnik AG Customer Service.

<https://www.buchi.com/contact>

## 1.1 Mark-ups and symbols



### NOTE

This symbol draws attention to useful and important information.

- ☑ This character draws attention to a requirement that must be met before the instructions below are carried out.
- ▶ This character indicates an instruction that must be carried out by the user.
- ⇒ This character indicates the result of a correctly carried out instruction.

Mark-up	Explanation
<i>Window</i>	Software Windows are marked-up like this.
<i>Tab</i>	Tabs are marked-up like this.
<i>Dialog</i>	Dialogs are marked-up like this.
<i>[Button]</i>	Buttons are marked-up like this.
<i>[Field names]</i>	Field names are marked-up like this.
<i>[Menu / Menu item]</i>	Menus or menu items are marked-up like this.
<b>Status</b>	Status is marked-up like this.
<b>Signal</b>	Signals are marked-up like this.

## 1.2 Trademarks

Product names and registered or unregistered trademarks that are used in this document are used only for identification and remain the property of the owner in each case.

## 1.3 Connected instruments

In addition to this operation manual, follow the instructions and specifications in the documentation for the connected instruments.

## 2 Safety

### 2.1 Proper use

The instrument is designed and built for laboratories.

The instrument detects light absorption behavior and works within a chromatography system.

### 2.2 Use other than that intended

The use of the instrument other than described in proper use and specified in technical data is use other than that intended.

The operator is responsible for damages or hazards that are caused by use other than that intended.

Especially the following uses are not permitted:

- Use of the instrument for processing substances outside of research and development.
- Use of the instrument in areas which require explosion-safe instruments.
- Use of the instrument with samples, which can explode or inflame (example: explosives, etc.) due to shock, friction, heat or spark formation.
- Use of the instrument with non-BUCHI instruments.
- Use of the instrument with toxic substances without appropriate safety measures.

### 2.3 Staff qualification

Unqualified persons are unable to identify risks and are therefore exposed to greater dangers.

The instrument may only be operated by suitably qualified laboratory staff.

These operating instructions are aimed at the following target groups:

#### Users

Users are persons that meet the following criteria:

- They have been instructed in the use of the instrument.
- They are familiar with the contents of these operating instructions and the applicable safety regulations and apply them.
- They are able on the basis of their training or professional experience to assess the risks associated with the use of the instrument.

#### Operator

The operator (generally the laboratory manager) is responsible for the following aspects:

- The instrument must be correctly installed, commissioned, operated and serviced.
- Only suitably qualified staff may be assigned the task of performing the operations described in these operating instructions.
- The staff must comply with the local applicable requirements and regulations for safe and hazard-conscious working practices.
- Safety-related incidents that occur while using the instrument should be reported to the manufacturer (quality@buchi.com).

#### BUCHI service technicians

Service technicians authorized by BUCHI have attended special training courses and are authorized by BÜCHI Labortechnik AG to carry out special servicing and repair measures.

## 2.4 Residual risks

The instrument has been developed and manufactured using the latest technological advances. Nevertheless, risks to persons, property or the environment can arise if the instrument is used incorrectly.

Appropriate warnings in this manual serve to alert the user to these residual dangers.

### 2.4.1 Flow cell breakage

Exceeding the max. operating pressure of 3 bar can cause the flow cell to break.

- ▶ Do not exceed the max. operating pressure.

### 2.4.2 Leaking liquids

Solvent lines and fittings can break during operation.

Fittings that are not secured tightly can cause leakage.

Incorrectly installed solvent lines can cause leakage. Leaking water or moisture can lead to a short circuit.

The packaging for transport is designed to prevent condensation.

- ▶ Make sure that the fittings are tight during installation.
- ▶ Frequently check the solvent lines and fittings.
- ▶ Immediately replace broken solvent lines and fittings before continuing operation.

### 2.4.3 Aggressive solvents

Leaving aggressive solvents such as dichloromethane in the chromatography system can cause instrument damage.

- ▶ Rinse the instrument with isopropanol after the use of aggressive solvents.
- ▶ Do not leave aggressive solvents inside the chromatography system.

### 2.4.4 UV radiation

Handling the instrument incorrectly can cause UV light radiation.

- ▶ Handle the instrument only as described in the operation manual and operation manuals of connected instruments.

### 2.4.5 Dangerous solvents

The use of the instrument with solvents can produce dangerous vapors that are hazardous to health.



Direct contact with solvents and the inhalation of solvents can cause burns or eye injury.

- ▶ Only operate the instrument wearing safety goggles, protective gloves resistant to the solvent and protective clothing.
- ▶ Only operate the instrument in well ventilated areas.
- ▶ Do not inhale any vapors produced during processing.
- ▶ Do not process any unknown fluids.
- ▶ Observe the safety data sheets for all substances used.
- ▶ If solvents leak, check the connections and replace them if necessary.

## 2.5 Warning symbols

The following warning symbols are displayed in this operation manual or on the instrument.

Symbol	Meaning
	General warning

Symbol	Meaning
	Instrument damage
	UV radiation
	Read manual

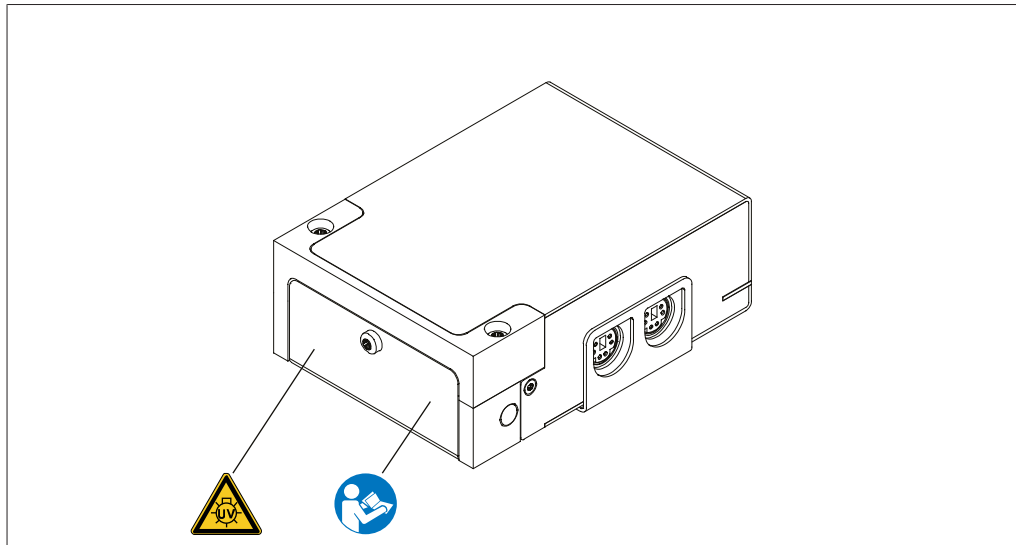

Fig. 1: Location of the warning symbols

## 2.6 Personal protective equipment

Depending on the application, hazards due to heat and/or corrosive chemicals may arise.

- ▶ Always wear appropriate personal protective equipment such as safety goggles, protective clothing and gloves.
- ▶ Make sure that the personal protective equipment meets the requirements of the safety data sheets for all chemicals used.

## 2.7 Modifications

Unauthorized modifications can affect safety and lead to accidents.

- ▶ Use only genuine BUCHI accessories, spare parts and consumables.
- ▶ Carry out technical changes only with prior written approval from BUCHI.
- ▶ Only allow changes to be made by BUCHI service technicians.

BUCHI accepts no liability for damage, faults and malfunctions resulting from unauthorized modifications.



## 3 Product description

### 3.1 Description of function

Pure UV Detector C-107 (Pure UV Detector) detects and measures changes in the light absorption behavior of liquids. The absorption at four wavelengths can be measured simultaneously:

- 254 nm
- 275 nm
- 325 nm
- 365 nm

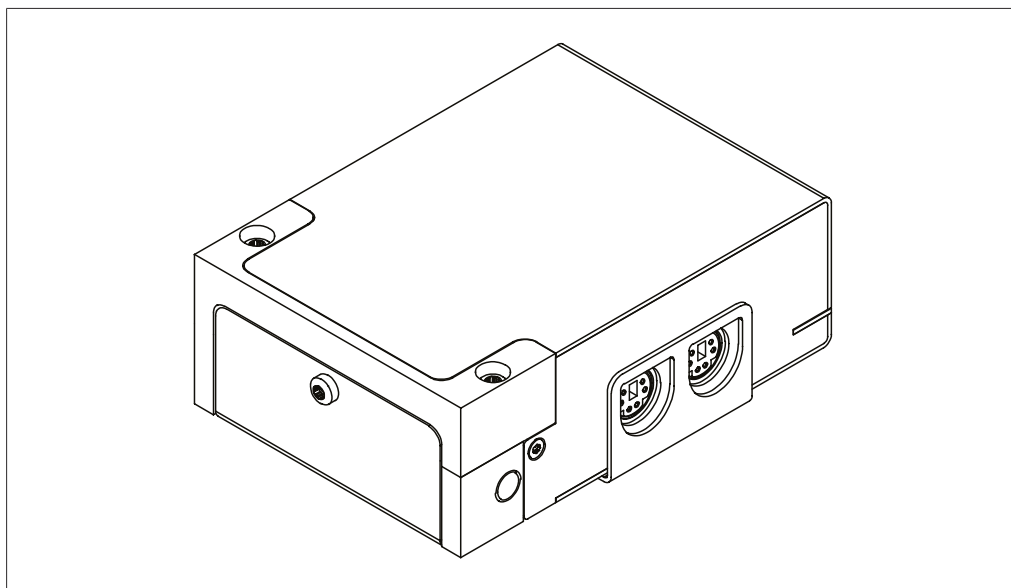

Fig. 2: Pure UV Detector

The instrument works within a modular chromatography system designed to purify complex samples by flash chromatography. Flash chromatography has the ability to separate gram sized samples in a short period of time.

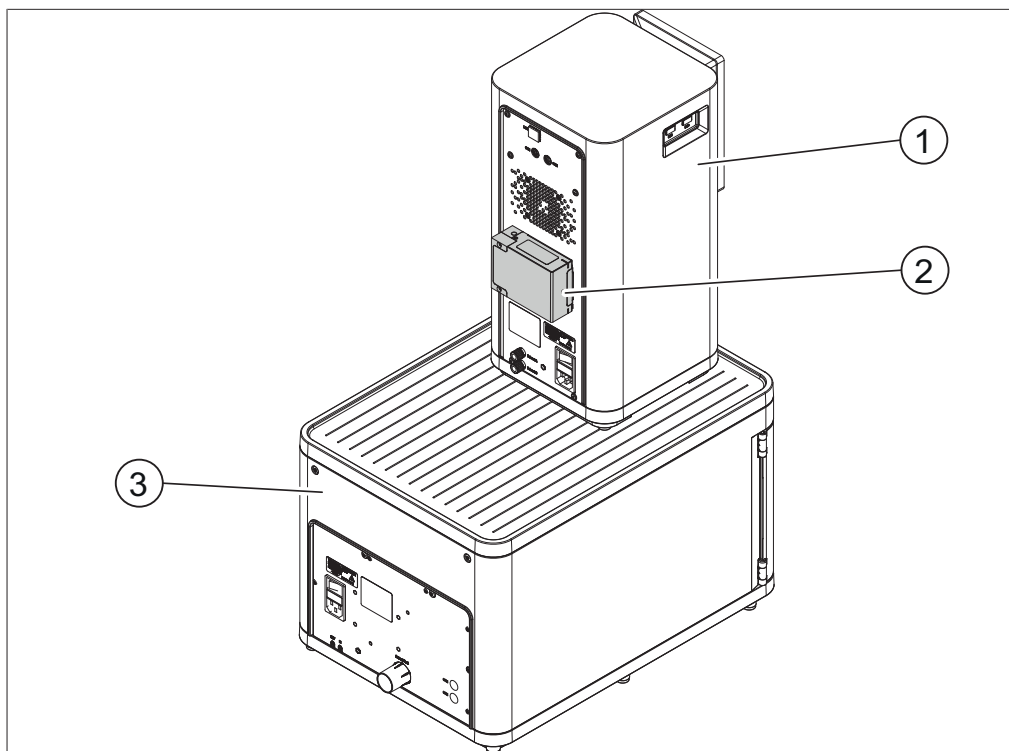

Fig. 3: Chromatography system (rear view)

- |   |                           |   |                  |
|---|---------------------------|---|------------------|
| 1 | Pure Chromatography C-900 | 2 | Pure UV Detector |
| 3 | Pure Fraction Collector   |   |                  |



**NOTE**

Pure UV Detector can only operate in conjunction with an appropriate Pure system able to control Pure UV Detector (e.g. Pure Chromatography C-900). The complete upgrade additionally includes Pure Fraction Collector.

The chromatography system allows:

- Using two different solvents
- Injecting liquid or solid samples
- Separating samples on a cartridge
- Identifying the compounds by UV detection
- Collecting the desired fractions

Please refer to the separate operation manuals for additional information on the other instruments.

### 3.2 Front view

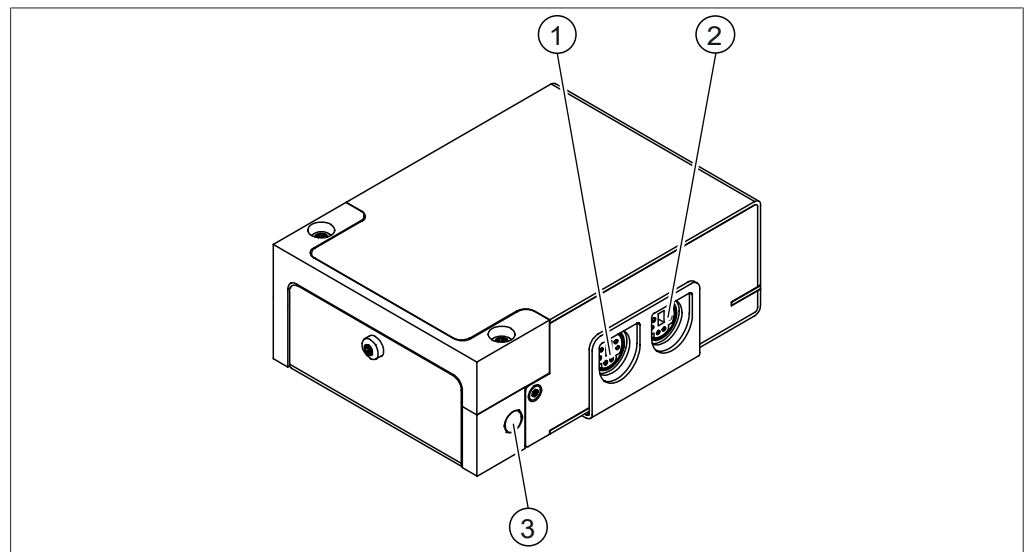

Fig. 4: Front view

- |   |                    |   |                   |
|---|--------------------|---|-------------------|
| 1 | Signal connection  | 2 | Signal connection |
| 3 | Solvent line inlet |   |                   |

### 3.3 Rear view

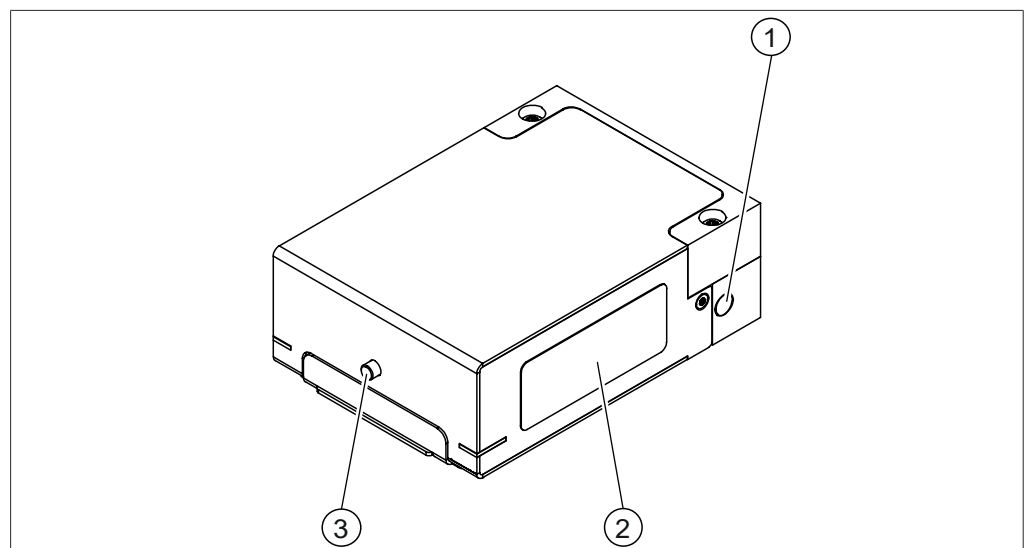

Fig. 5: Rear view

- |   |                     |   |   |
|---|---------------------|---|---|
| 1 | Solvent line outlet | 2 | Type plate<br>See Chapter 3.5 "Type plate",<br>page 12. |
| 3 | Push rod            |   |   |

### 3.4 Scope of delivery



#### NOTE

The scope of delivery depends on the configuration of the purchase order.

Accessories are delivered as per the purchase order, order confirmation, and delivery note.

### 3.5 Type plate

The type plate identifies the instrument. The type plate is located at the rear of the instrument. See Chapter 3.3 "Rear view", page 11.

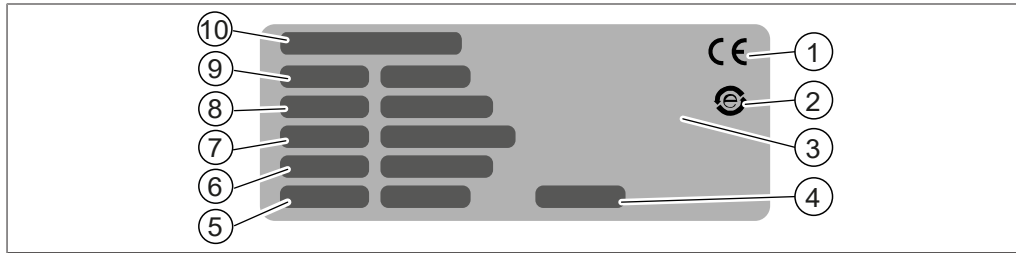

Fig. 6: Type plate

- |   |   |    |                                    |
|---|---|----|------------------------------------|
| 1 | Symbol for CE conformity                          | 2  | Symbol for "electronics recycling" |
| 3 | Symbol for "Do not dispose of as household waste" | 4  | Year of manufacture                |
| 5 | Power consumption maximum                         | 6  | Frequency                          |
| 7 | Input voltage range                               | 8  | Serial number                      |
| 9 | Instrument name                                   | 10 | Company name and address           |

### 3.6 Technical data

#### 3.6.1 Pure UV Detector C-107

Specification	Value
Dimensions (W x D x H)	100 x 70 x 35 mm
Weight	0.5 kg
Power consumption	0.3 W
Supply voltage	12 – 36 VDC
Max. operating pressure	3 bar
Wavelength UV1	254 nm
Wavelength UV2	275 nm
Wavelength UV3	325 nm
Wavelength UV4	365 nm
Hose connections	2 UNF 1/4"-28
Interfaces	2 BUCHI standard communication ports (COM)

#### 3.6.2 Ambient conditions

For indoor use only.

Specification	Value
Max. altitude above sea level	2,000 m
Ambient and storage temperature	5 – 40 °C
Maximum relative humidity	80% for temperatures up to 31 °C decreasing linearly to 50% relative humidity at 40 °C

### 3.6.3 Materials

Component	Material
Housing	Stainless steel 1.4301 (AISI 304)
Gear head	Aluminum cast (3.2373)
Painting	Powder coated with Epoxy (EPX)
Bath pan	Stainless steel 1.4404 (AISI 316L)
Heating element	Stainless steel 1.4404 (AISI 316L)
Glass	Borosilicate 3.3 (UV grade fused silica)
In contact with product	FDA approved materials
Machined parts	Stainless steel 1.4305
Plastic parts machined	PEEK (Polyether ether ketone)
Sealings	FFKM (Perfluoroelastomer)
Rubber parts	EPDM (Ethylene propylene rubber)

### 3.6.4 Installation site

- The installation site has enough space that cables / tubes can be routed safely.
- The installation site has no obstacles (e.g. water taps, drains, etc.).
- The installation site is not exposed to external thermal loads, such as direct solar radiation.
- The installation site meets the requirements for the connected instruments. See related documentation.
- The installation site meets the requirements of the safety data sheets for all solvents and samples used.
- The installation site meets the safety requirements. See Use other than intended.
- The installation site meets the specifications according to the technical data (e.g. weight, dimension, etc.). See Chapter 3.6 "Technical data", page 12.
- The installation site and the instrument meet the requirements for the EMC environment, Basic electromagnetic environment / Emission Class B.

## 4 Transport and storage

### 4.1 Transport



#### NOTICE

##### Risk of breakage due to incorrect transportation

- ▶ Make sure that all parts of the instrument are safely packed in such a way as to prevent breakage, ideally in the original box.
- ▶ Avoid sharp movements during transit.

- 
- ▶ After transportation, check the instrument for damage.
  - ▶ Damage that has occurred in transit should be reported to the carrier.
  - ▶ Keep packing for future transportation.

### 4.2 Storage

- ▶ Make sure that the ambient conditions are complied with (see Chapter 3.6 "Technical data", page 12).
- ▶ Wherever possible, store the instrument in its original packaging.
- ▶ After storage, check the instrument, all seals and tubing for damage and replace if necessary.

## 5 Installation

### 5.1 Installing the instrument on Pure Chromatography C-900

- ▶ Loosen the screw on the cover.

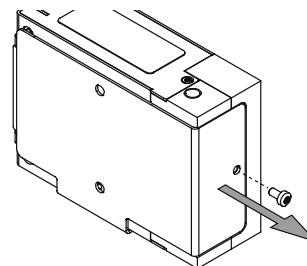

- ▶ Remove the cover.

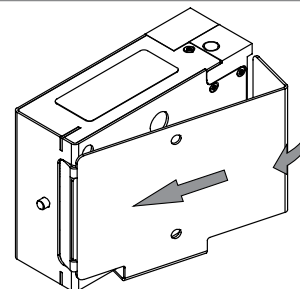

- ▶ Mount the cover on the back of the Pure Chromatography C-900 with two screws.

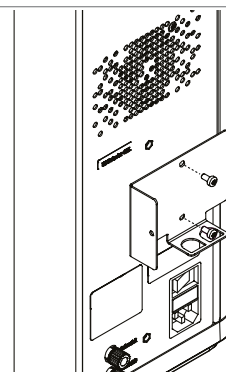

- ▶ Place the Pure UV Detector back into the cover.
- ▶ Tighten the screw on the cover again.

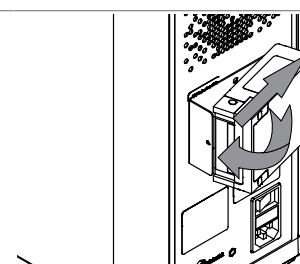

### 5.2 Connecting the instrument within a chromatography system



#### NOTE

Connection within a chromatography system

Please refer to the Pure Chromatography C-900 operation manual for additional information on the installation.

## 6 Operation

All functions of the instrument are controlled by the chromatography system software. Please refer to the Pure Chromatography C-900 operation manual for additional information.



## 7 Cleaning and servicing



### NOTE

- ▶ Carry out only the service and cleaning operations described in this section.
- ▶ Do not carry out any servicing and cleaning operations that involve opening the housing.
- ▶ Use only genuine BUCHI spare parts in order to ensure correct operation and preserve the warranty.
- ▶ Carry out the service and cleaning operations described in this section to extend the lifetime of the instrument.

### 7.1 Regular maintenance work

Action	Weekly	Twice a year	Additional information
7.2 Cleaning the housing	1		
7.3 Cleaning the flow cell			1 When necessary
7.4 Replacing the flow cell			1 When necessary, in case of breakage

1 - Operator

### 7.2 Cleaning the housing

- ▶ Wipe down the housing with a damp cloth.
- ▶ If heavily soiled, use ethanol or a mild detergent.

### 7.3 Cleaning the flow cell



#### **WARNING**

#### **Injury hazard from broken glass**

Direct contact with broken glass can cause cuts.

- ▶ Wear protective gloves.



### NOTE

Use of ethanol and acetone when removing protein

It is not recommended to use ethanol or acetone at the beginning of a cleaning procedure when cleaning flow cells stained with protein.

- ▶ Thoroughly rinse the flow cell with deionized water first.
- ▶ Rinse the flow cell with ethanol or acetone.

A contaminated flow cell has decreased transmissivity. This causes increased noise levels, decreased response, and difficulties setting UV to zero.

To remove the flow cell for cleaning, follow the instructions for the flow cell replacement. See Chapter 7.4 "Replacing the flow cell", page 18.

### Cleaning agents

- Dilute acid: Dilute hydrochloric acid, nitric acid
- Copious water: Deionized water, distilled water, RO water
- Solvent: The same solvent which was used to solvate the sample
- Tissue: Lens cleaning tissue, fine wiper cloth

### Cleaning procedure

Depending on the residual material to be removed, a different cleaning procedure is recommended.

Solution	Sample type	Cleaning procedure
Aqueous	Protein, DNA, RNA, biologics	<ul style="list-style-type: none"> <li>▶ Empty the flow cell.</li> <li>▶ Rinse the flow cell with dilute acid.</li> <li>▶ Rinse the flow cell with water.</li> <li>▶ Repeat the previous steps 2 - 3 times.</li> </ul> <p>If the protein is still not completely removed from the flow cell:</p> <ul style="list-style-type: none"> <li>▶ Incubate the flow cell in trypsin over night at room temperature.</li> <li>▶ Rinse the flow cell with water.</li> <li>▶ Rinse the flow cell with ethanol.</li> </ul>
Aqueous	Salt solutions	<ul style="list-style-type: none"> <li>▶ Rinse the flow cell with warm water.</li> <li>▶ Rinse the flow cell with copious water.</li> <li>▶ Repeat the previous steps 2 - 3 times.</li> </ul>
Organic	Alcohol solutions	<ul style="list-style-type: none"> <li>▶ Place the flow cell underneath a fume hood.</li> <li>▶ Rinse the flow cell with solvent used during operation.</li> <li>▶ Rinse the flow cell with copious water.</li> <li>▶ Repeat the previous steps 2 - 3 times.</li> </ul>
	Soluble samples	<ul style="list-style-type: none"> <li>▶ Rinse the flow cell with distilled water.</li> <li>▶ To prevent water spots, rinse the flow cell with ethanol.</li> <li>▶ To accelerate the drying, rinse the flow cell with acetone.</li> <li>▶ Dry and carefully tap the flow cell on a lint-free paper towel.</li> </ul>

## 7.4 Replacing the flow cell



### WARNING

#### Injury hazard from broken glass

Direct contact with broken glass can cause cuts.

- ▶ Wear protective gloves.

In case of breakage, the flow cell must be replaced.

Precondition:

- The instrument is disconnected from any other instruments.
- ▶ Remove the screw.

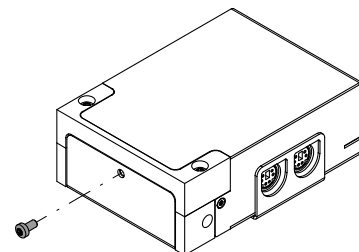

- ▶ Remove the bottom cover.

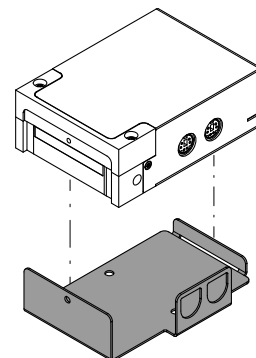

- ▶ Loosen the two screws securing the top cover.
- ▶ Lift up the top cover to release the flow cell.

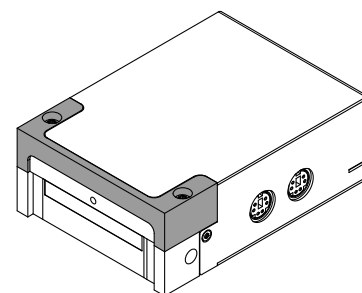

- ▶ Push in the push rod.

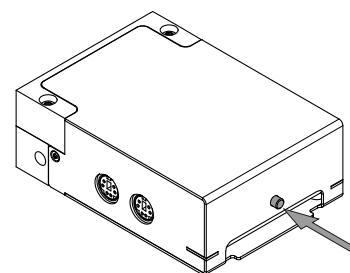

- ▶ Remove the flow cell to examine/clean it.

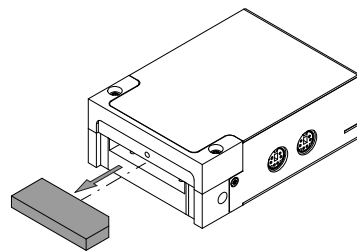

- ▶ Insert the new/cleaned flow cell paying attention to the chamfer orientation.
- ▶ Tighten the two screws on the top cover again.
- ▶ Mount the bottom cover back on.

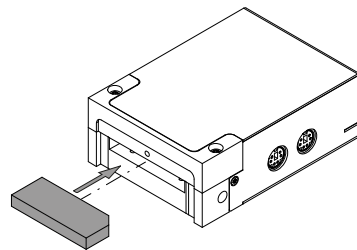

## 8 Help with faults

### 8.1 Faults, possible causes and solutions

All functions of the instrument are controlled by the chromatography system software. Please also refer to the Pure Chromatography C-900 operation manual for additional information.

Malfunction	Possible cause	Solution
Low UV signal Low transmissivity Noise during operation UV to zero not working properly	Flow cell is soiled	Clean the flow cell. See Chapter 7.3 "Cleaning the flow cell", page 17.
Leakage Signal distortion	O-ring is brittle	Contact BUCHI service technician.
Loss of function	Housing is damaged	Contact BUCHI service technician.
Flow cell is difficult to remove or not possible	Push rod is damaged or soiled	Contact BUCHI service technician.

### 8.2 Customer service

Only authorized service personnel are allowed to perform repair work on the device which is not described in this manual. Authorization requires a comprehensive technical training and knowledge of possible dangers which might arise when working at the device. Such training and knowledge can only be provided by BUCHI.

The customer service and support offers the following support:

- Spare part delivery
- Repairs
- Technical advice

Addresses of official BUCHI customer service offices can be found on the BUCHI website.

[www.buchi.com](http://www.buchi.com)

## 9 Taking out of service and disposal

### 9.1 Taking out of service

- ▶ Remove all tubing and communication cables from the instrument.
- ▶ Remove the instrument from the chromatography system.

### 9.2 Disposal

The operator is responsible for proper disposal of the instrument.

- ▶ When disposing the equipment observe the local regulations and statutory requirements regarding waste disposal.
- ▶ When disposing, observe the disposal regulations of the materials used. Materials used see Chapter 3.6 "Technical data", page 12.

### 9.3 Returning the instrument

Before returning the instrument, contact the BÜCHI Labortechnik AG Service Department.

<https://www.buchi.com/contact>

## 10 Appendix

### 10.1 Spare parts and accessories

Use only genuine BUCHI consumables and spare parts in order to ensure correct, safe and reliable operation of the system.



#### NOTE

Any modifications of spare parts or assemblies are only allowed with the prior written permission of BUCHI.

#### 10.1.1 Spare parts

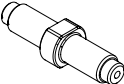
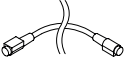
	Order no.	Image
Male union UNF 1/4"-28	11068367	
Communication cable. BUCHI COM, 0.9 m, 6p Enables connection between Rotavapor® R-300 / R-220 Pro, Interface I-300 / I-300 Pro, Vacuum Pump V-300 / V-600, Recirculating Chiller F-3xx, VacuBox and LegacyBox. Enables connection between Pure® Chromatography C-900, Fraction Collector, UV Detector.	11070540	

#### 10.1.2 Accessories

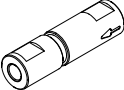
	Order no.	Image
Back pressure regulation valve (2 bar)	11068403	
Flow cell 0.3 mm Essential line	11073975	

---

We are represented by more than 100 distribution partners worldwide.  
Find your local representative at:

[www.buchi.com](http://www.buchi.com)

Quality in your hands

---