

Operation Manual

SyncorePlus



Imprint

Product Identification:
Operation Manual (Original) SyncorePlus
11594118

Publication date: 04.2024

Version D

BÜCHI Labortechnik AG
Meierseggstrasse 40
Postfach
CH-9230 Flawil 1
E-Mail: quality@buchi.com

BUCHI reserves the right to make changes to the manual as deemed necessary in the light of experience, especially with respect to structure, illustrations and technical details.

This manual is copyrighted. Information from it may neither be reproduced, distributed, or used for competitive purposes, nor made available to third parties. The manufacture of any component with the aid of this manual without prior written agreement is also prohibited.

Table of contents

1	About this document.....	6
1.1	Warning notices in this document.....	6
1.2	Symbols.....	6
1.2.1	Warning symbols.....	6
1.2.2	Mark-ups and symbols.....	7
1.3	Trademarks.....	7
1.4	Connected instruments.....	7
2	Safety.....	8
2.1	Proper use.....	8
2.2	Use other than intended.....	8
2.3	Location of warning signs on the product.....	9
2.4	Protection devices.....	10
2.5	Staff qualification.....	10
2.6	Residual risks.....	11
2.6.1	Glass breakage.....	11
2.6.2	Faults during operation.....	11
2.6.3	Hot surfaces.....	11
2.6.4	Dangerous vapors.....	11
2.6.5	High internal pressure.....	12
2.6.6	Rotating parts.....	12
2.7	Personal protective equipment.....	12
2.8	Modifications.....	12
3	Product description.....	13
3.1	Description of function.....	13
3.2	Configuration.....	14
3.2.1	Front view.....	14
3.2.2	Rear view.....	15
3.2.3	Cover.....	16
3.3	Type plate.....	17
3.4	Scope of delivery.....	17
3.5	Technical data.....	17
3.5.1	SyncorePlus.....	17
3.5.2	Ambient conditions.....	18
3.5.3	Materials.....	18
4	Transport and storage.....	19
4.1	Transport.....	19
4.2	Storage.....	19
4.3	Lifting the instrument.....	19

5	Installation	20
5.1	Before installation	20
5.2	Installation site	20
5.3	Establishing electrical connections	20
5.4	Securing against earthquakes	21
5.5	Connecting the instrument to the control system.....	21
5.6	Installing the condenser.....	21
5.6.1	Installing the condenser	21
5.6.2	Connecting the coolant to the condenser	22
5.6.3	Connecting the vacuum pump to the condenser	23
5.6.4	Connecting the vacuum hose for the heater cover	23
5.6.5	Installing the cap nut (Polyvap and Analyst configuration only).....	23
5.6.6	Installing the vapor sensor (Option).....	23
5.7	Installing the waste vessel (SPE configuration only)	24
6	Preparing the instrument for a configuration	27
6.1	Preparing a Polyvap configuration.....	27
6.2	Preparing an Analyst configuration.....	29
6.3	Preparing a SPE configuration	32
6.3.1	Position SPE advanced valves	34
7	Operation	35
7.1	Operating the control panel	35
7.1.1	Layout of the control panel.....	35
7.1.2	Status panel	35
7.1.3	Setting the evaporation temperature.....	36
7.1.4	Setting the cooling water follow-up time	36
7.2	Carrying out an evaporation (with control system)	36
7.3	Carrying out an evaporation (without control system)	36
7.3.1	Preparing the instrument.....	37
7.3.2	Starting an evaporation.....	37
7.3.3	Ending an evaporation	37
7.3.4	Shutting down the instrument	37
8	Cleaning and servicing	38
8.1	Regular maintenance work	38
8.2	Locking and unlocking the rotation	39
8.3	Moving and retrieving the heating plate into a pre-defined position	39
8.4	Adjusting the unbalance compensation	39
8.5	Testing the vortex movement	40
9	Help with faults	41
9.1	Troubleshooting	41
9.2	Error messages	42
9.3	Changing the fuse.....	44
10	Taking out of service and disposal	45
10.1	Taking out of service.....	45
10.2	Disposal	45
10.3	Returning the instrument	45

11	Appendix	46
11.1	Schematics	46
11.1.1	Cooling	46
11.1.2	Communication connections	46
11.2	Spare parts and accessories	47
11.2.1	Racks	47
11.2.2	Cover	49
11.2.3	Flushback Module	50
11.2.4	Tubes	50
11.2.5	Gaskets and plugs	52
11.2.6	Sample preparation rack	53
11.2.7	Condenser	54
11.2.8	Receiving flask	54
11.2.9	Cocking lever	54
11.2.10	Sleeves	54
11.2.11	Accessories SPE configuration	55
11.2.12	Sensors	57
11.2.13	Tubing	58
11.2.14	Hose barbs	58
11.2.15	Tools	59
11.2.16	Service	59

1 About this document

This operation manual is applicable for all variants of the instrument.

Read this operation manual before operating the instrument and follow the instructions to ensure safe and trouble-free operation.

Keep this operation manual for later use and pass it on to any subsequent user or owner.

BÜCHI Labortechnik AG accepts no liability for damage, faults and malfunctions resulting from not following this operation manual.

If you have any questions after reading this operation manual:

► Contact BÜCHI Labortechnik AG Customer Service.

<https://www.buchi.com/contact>

1.1 Warning notices in this document

Warning notices warn you of dangers that can occur when handling the instrument.







There are four danger levels, each identifiable by the signal word used.

Signal word	Meaning
DANGER	Indicates a danger with a high level of risk which could result in death or serious injury if not prevented.
WARNING	Indicates a danger with a medium level of risk which could result in death or serious injury if not prevented.
CAUTION	Indicates a danger with a low level of risk which could result in minor or medium-severity injury if not prevented.
NOTICE	Indicates a danger that could result in damage to property.

1.2 Symbols

The following symbols are displayed in this operation manual or on the device:

1.2.1 Warning symbols

Symbol	Meaning
	General warning
	Instrument damage
	Hot surface
	Hand injuries
	Dangerous electrical voltage
	Breakable items

Symbol	Meaning
	Explosive substances

1.2.2 Mark-ups and symbols



NOTE

This symbol draws attention to useful and important information.

- ☑ This character draws attention to a requirement that must be met before the instructions below are carried out.
- ▶ This character indicates an instruction that must be carried out by the user.
- ⇒ This character indicates the result of a correctly carried out instruction.

Mark-up	Explanation
<i>Window</i>	Software Windows are marked-up like this.
<i>Tab</i>	Tabs are marked-up like this.
<i>Dialog</i>	Dialogs are marked-up like this.
<i>[Button]</i>	Buttons are marked-up like this.
<i>[Field names]</i>	Field names are marked-up like this.
<i>[Menu / Menu item]</i>	Menus or menu items are marked-up like this.
Status	Status is marked-up like this.
Signal	Signals are marked-up like this.

1.3 Trademarks

Product names and registered or unregistered trademarks that are used in this document are used only for identification and remain the property of the owner in each case.

1.4 Connected instruments

In addition to this operation manual, follow the instructions and specifications in the documentation for the connected instruments.

2 Safety

2.1 Proper use

The instrument is designed and built for laboratories.

The instrument can be used for the following tasks:

- Parallel evaporation of solvents in various formats and containers across a range of temperatures from room temperature up to + 100 °C and within a range of pressures from 1 mbar up to ambient pressure.
- Evaporation and recycling of solvents.
- Concentration of extracts.
- Drying of powders and granulates.
- Purification of chemicals.

2.2 Use other than intended

Use of any kind other than that described in Chapter 2.1 “Proper use”, page 8 and any application that does not comply with the technical specifications (Chapter 3.5 “Technical data”, page 17) constitutes use other than intended.

In particular, the following applications are not permissible:

- Use of the instrument in rooms which require ex-protected instruments.
- Use of samples, which can explode or inflame (example: explosives, etc.) due to shock, friction, heat or spark formation.
- Use of the instrument with solvents containing peroxides.
- Use of the instrument in overpressure situations.
- Use of the instrument as a reactor platform.

The use of the instrument other than described in proper use and specified in technical data is use other than that intended.

The operator is responsible for damages or hazards that are caused by use other than that intended.

Especially the following uses are not permitted:

2.3 Location of warning signs on the product

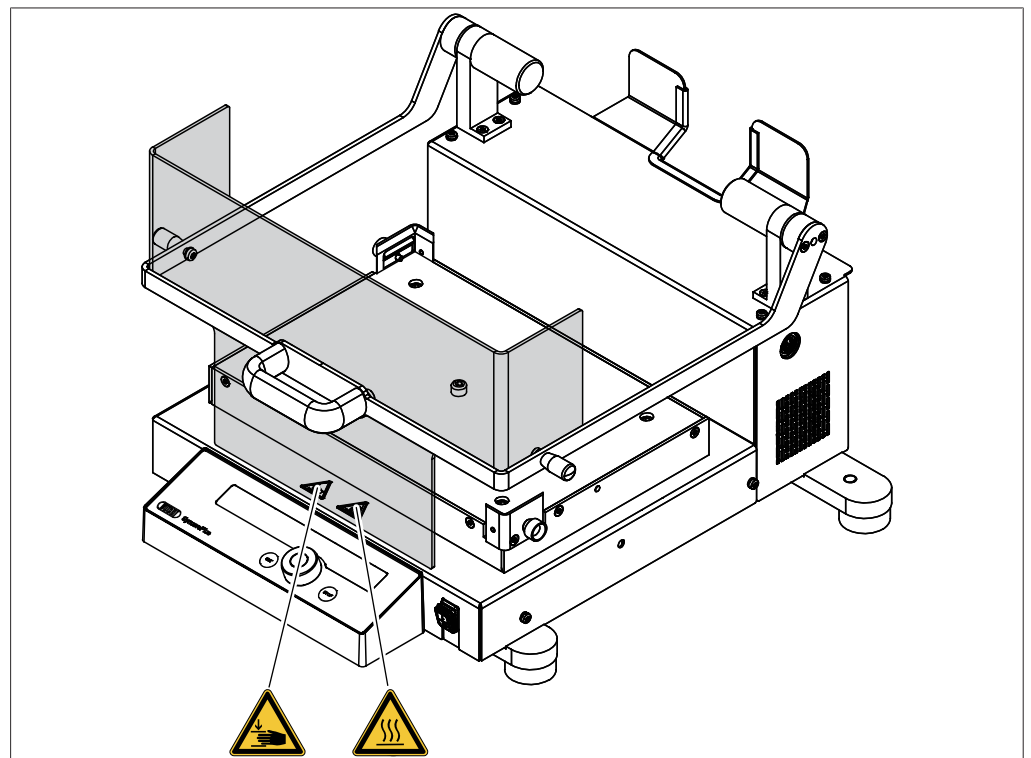



Fig. 1: Location of warning signs

Symbol	Meaning
	Hot surface
	Hand injuries

2.4 Protection devices

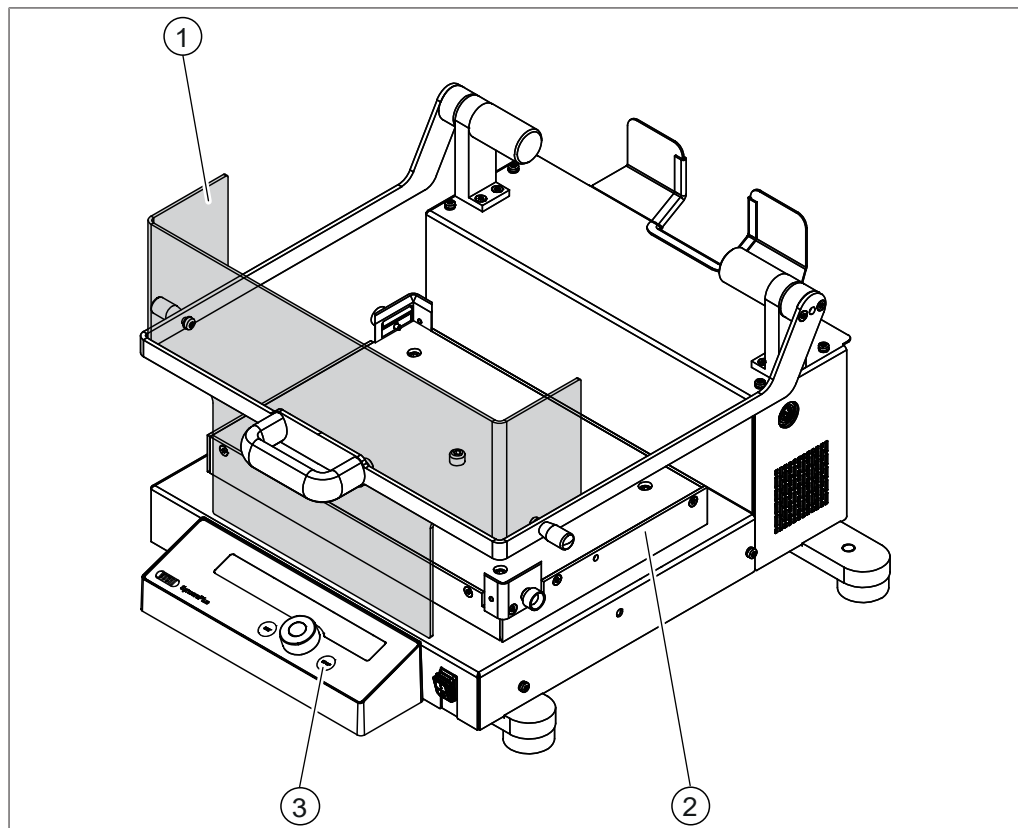

Fig. 2: Protection devices

- | | | | |
|---|--------------------|---|------------------|
| 1 | Protective cover | 2 | Crush protection |
| 3 | Button STOP | | |

2.5 Staff qualification

Unqualified persons are unable to identify risks and are therefore exposed to greater dangers.

The instrument must be operated by suitably qualified laboratory staff.

These operating instructions are aimed at the following target groups:

Users

The users are persons that meet the following criteria:

- They have been instructed in the use of the instrument.
- They are familiar with the contents of these operating instructions and the applicable safety regulations and apply them.
- They are able on the basis of their training or professional experience to assess the risks associated with the use of the instrument.

Operator

The operator (generally the laboratory manager) is responsible for the following aspects:

- The instrument must be correctly installed, commissioned, operated and serviced.
- Only suitably qualified staff must be assigned the task of performing the operations described in these operating instructions.
- The staff must comply with the local applicable requirements and regulations for safe and hazard-conscious working practices.
- Safety-related incidents that occur while using the instrument should be reported to the manufacturer (quality@buchi.com).

BUCHI service technicians

Service technicians authorized by BUCHI have attended special training courses and are authorized by BÜCHI Labortechnik AG to carry out special servicing and repair measures.

2.6 Residual risks

The instrument has been developed and manufactured using the latest technological advances. Nevertheless, risks to persons, property or the environment can arise if the instrument is used incorrectly.

Appropriate warnings in this manual serve to alert the user to these residual dangers.

2.6.1 Glass breakage

Broken glass can cause severe cuts.

Minor damage to the ground joints impairs the sealing effect and may therefore diminish suction capacity.

- Handle the glass components carefully and do not drop them.
- Always place the glassware in a suitable holder when they are not in use.
- Always visually inspect glass components for damage every time they are to be used.
- Do not continue to use glass components that are damaged.
- Always wear protective gloves when disposing of broken glass.

2.6.2 Faults during operation

If an instrument is damaged, sharp edges, glass splinters, moving parts or exposed electrical wires can cause injuries.

- ▶ Regularly check instruments for visible damage.
- ▶ If faults occur, switch off the instrument immediately, unplug the power cord and inform the operator.
- ▶ Do not continue to use instruments that are damaged.

2.6.3 Hot surfaces

The surfaces of the instrument can become hot. If touched they can cause skin burns.

- ▶ Do not touch hot surfaces or wear suitable protective gloves.

2.6.4 Dangerous vapors

Distillation can produce dangerous vapors that are capable of causing life-threatening toxic effects.

- ▶ Do not inhale any vapors produced during distillation.
- ▶ Ensure that vapors are removed by a suitable fume hood.
- ▶ Only use the device in well ventilated areas.
- ▶ If vapors escape from joints or connections, check the seals concerned and replace them if necessary.

- ▶ Do not distill any unknown fluids.
- ▶ Observe the safety data sheets for all fluids used.

2.6.5 High internal pressure

The evaporation of fluids can produce high pressures inside the tubes or the condenser. If that pressure becomes too great, the glass components could explode.

- ▶ Make sure that the internal pressure inside the glass components is never greater than atmospheric pressure.
- ▶ When distilling without a vacuum, set the vacuum pump to atmospheric pressure so that excess pressure is automatically dissipated.
- ▶ If a vacuum pump is not used, leave the vacuum connection open.

2.6.6 Rotating parts

Hair, clothing or jewelry can become caught up if allowed to come into contact with the rotating parts.

At high speeds, the heating fluid may be sprayed out by the rotation.

- ▶ Wear work overalls or protective clothing.
- ▶ Do not wear loose or baggy items of clothing such as scarves or neck-ties.
- ▶ Tie up long hair.
- ▶ Do not wear jewelry such as necklaces or bracelets.
- ▶ At high speeds and/or high temperatures, use the additional protective arrangements.

2.7 Personal protective equipment

Depending on the application, hazards due to heat and/or corrosive chemicals may arise.

- ▶ Always wear appropriate personal protective equipment such as safety goggles, protective clothing and gloves.
- ▶ Make sure that the personal protective equipment meets the requirements of the safety data sheets for all chemicals used.

2.8 Modifications

Unauthorized modifications can affect safety and lead to accidents.

- ▶ Use only genuine BUCHI accessories, spare parts and consumables.
- ▶ Carry out technical changes only with prior written approval from BUCHI.
- ▶ Only allow changes to be made by BUCHI service technicians.

BUCHI accepts no liability for damage, faults and malfunctions resulting from unauthorized modifications.

3 Product description

3.1 Description of function

The instrument is a parallel evaporator which can carry out distillations of solvents in various formats and containers across a range of temperatures from room temperature up to + 100 °C and within a range of pressures from 1 mbar up to ambient pressure.

The basis of the process is the evaporation and condensing of solvents under vacuum.

- ▶ The product is heated in the rack.
- ▶ The even rotation of the rack induces a vortex on the surface of each liquid sample.
 - ⇒ By this vortex, the evaporation surface is enlarged and, therefore, the evaporation is accelerated.
 - ⇒ This also constantly mixes the product which prevents localized overheating and delayed evaporation.
- ▶ The vapor is converged and reheated in the cover.
- ▶ Then it passes on via the vacuum hose to the condenser.
- ▶ There, the latent heat of the vapor is transferred to the coolant fluid so that the vapor condenses.

3.2 Configuration

3.2.1 Front view

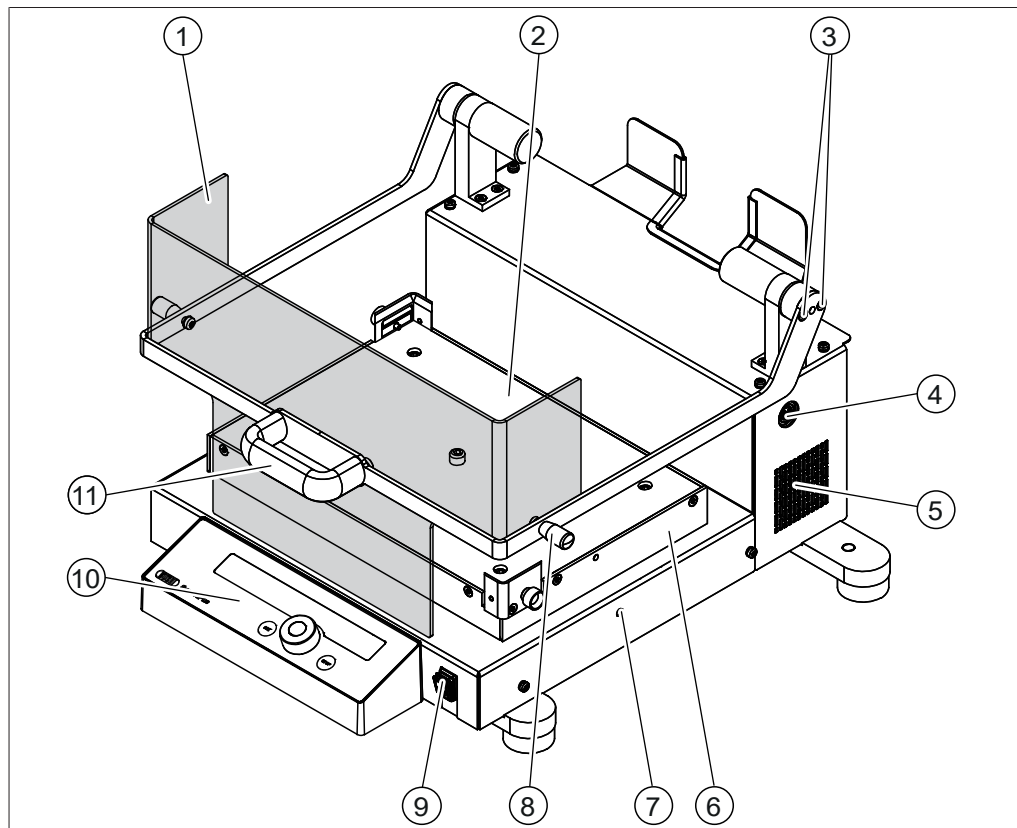

Fig. 3: Front view

- | | |
|-------------------------------------|---------------------------|
| 1 Protective cover | 2 Heating base |
| 3 Screws fixing cover | 4 Connection cover |
| 5 Venting slots | 6 Crush protection |
| 7 Unbalance compensation adjustment | 8 Handle protective cover |
| 9 On/Off master switch | 10 Control panel |
| 11 Handle protective cover | |

3.2.2 Rear view

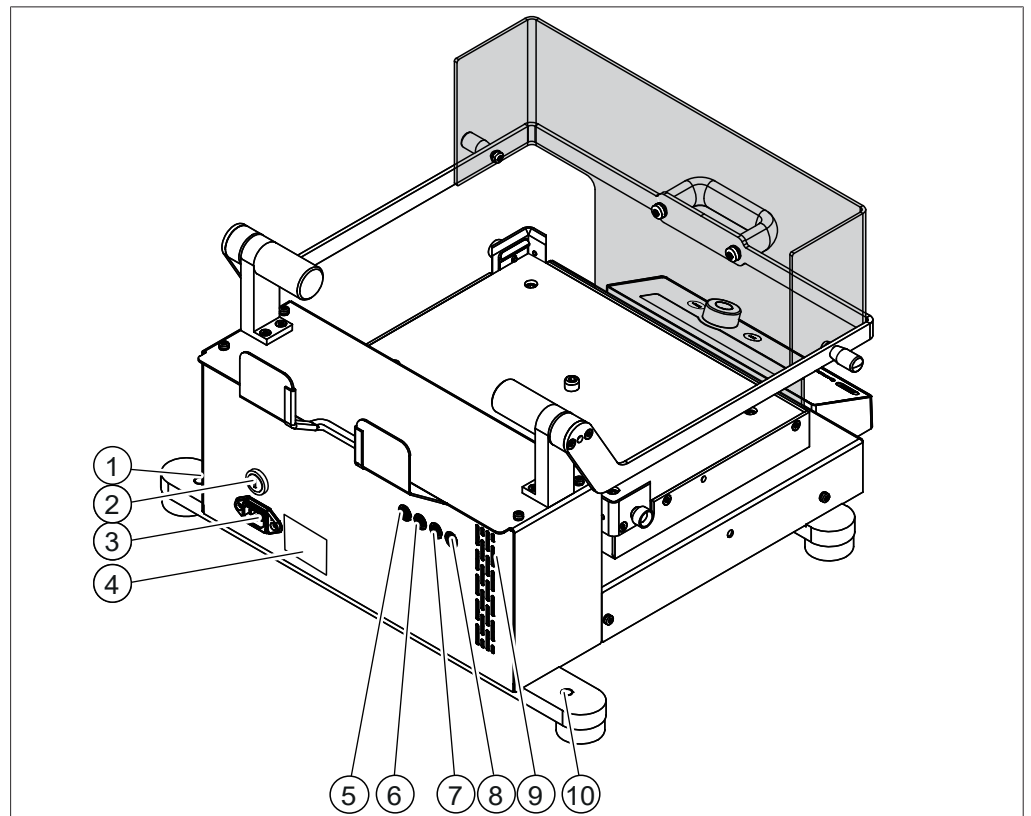

Fig. 4: Rear view

- | | |
|---|--|
| 1 Tap hole | 2 Fuse |
| 3 Mains power supply | 4 Type plate Chapter 3.3 "Type plate", page 17 |
| 5 BUCHI standard communication port (COM) | 6 BUCHI standard communication port (COM) |
| 7 Cooling water valve (marked CW) | 8 Reserve (marked AV) |
| 9 Ventilation slots | 10 Tap hole |

3.2.3 Cover

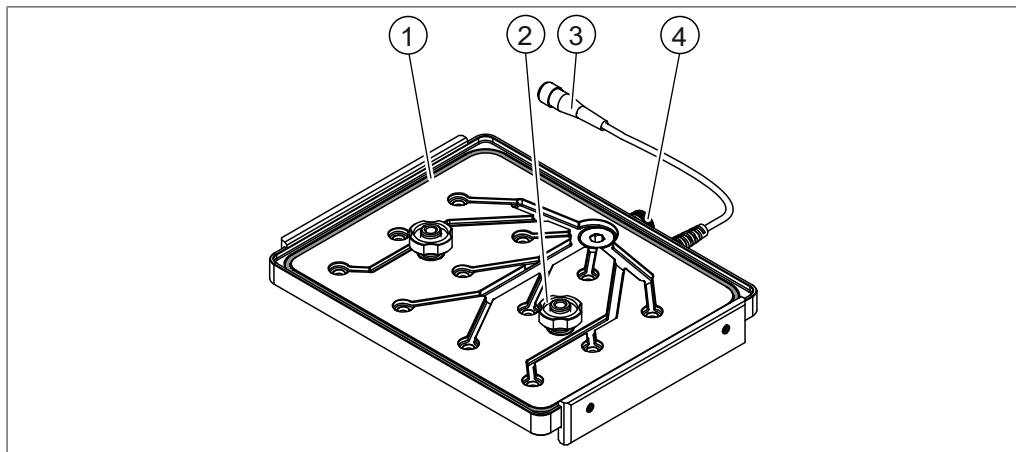

Fig. 5: Cover top

- | | | | |
|---|-----------------|---|-------------------|
| 1 | Sealing | 2 | Clamping nut |
| 3 | Connector cover | 4 | Vacuum connection |

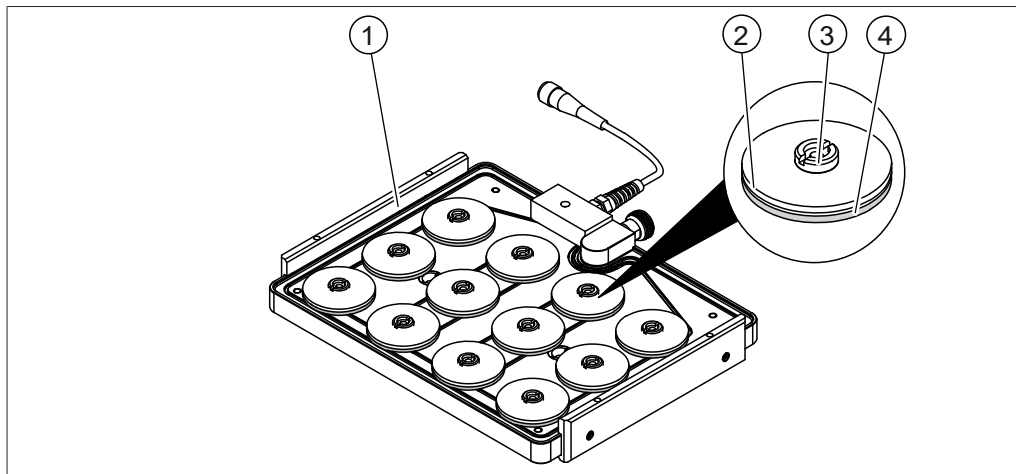

Fig. 6: Cover bottom

- | | | | |
|---|-----------|---|--------------|
| 1 | Handle | 2 | Sealing disk |
| 3 | Screw cap | 4 | Support disk |

3.3 Type plate

The type plate identifies the instrument. The type plate is located at the rear of the instrument. See Chapter 3.2.2 “Rear view”, page 15

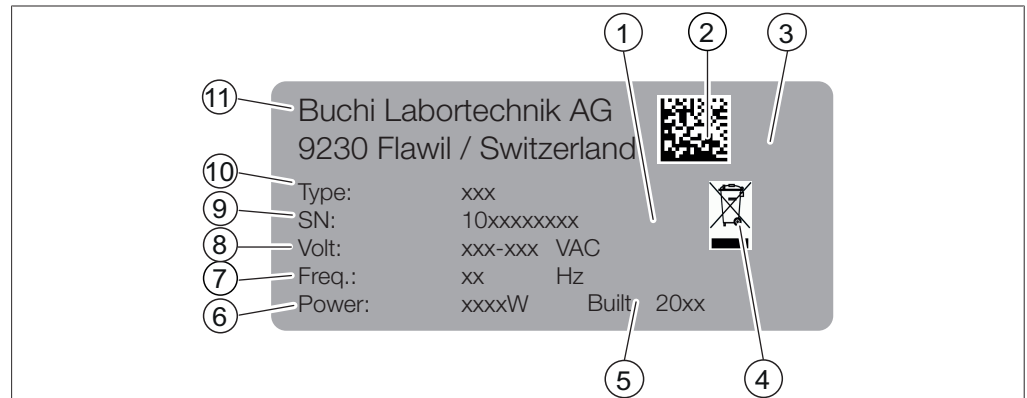

Fig. 7: Type plate

- | | | | |
|----|--------------------------|----|---|
| 1 | Approval | 2 | Product code |
| 3 | Approval | 4 | Symbol for "Do not dispose of as household waste" |
| 5 | Year of manufacture | 6 | Power consumption maximum |
| 7 | Frequency | 8 | Input voltage range |
| 9 | Serial number | 10 | Instrument name |
| 11 | Company name and address | | |

3.4 Scope of delivery



NOTE

The scope of delivery depends on the configuration of the purchase order.

Accessories are delivered as per the purchase order, order confirmation, and delivery note.

3.5 Technical data

3.5.1 SyncorePlus

	SyncorePlus 100 V	SyncorePlus 115 V	SyncorePlus 230 V
Dimensions (W x D x H) (main unit)	500 x 520 x 325 mm	500 x 520 x 325 mm	500 x 520 x 325 mm
Weight (main unit)	30 kg	30 kg	30 kg
Minimum clearance left & right	150 mm	150 mm	150 mm
Minimum clearance back	80 mm	80 mm	80 mm
Connection voltage	100 ± 10 % VAC	115 ± 10 % VAC	230 ± 10 % VAC
Frequency	50/60 Hz	50/60 Hz	50/60 Hz
Power consumption	1250 W	1250 W	1400 W
Power consumption heater cover	120 W	120 W	120 W
Rotation speed range	60 - 400 rpm	60 - 400 rpm	60 - 400 rpm

	SyncorePlus 100 V	SyncorePlus 115 V	SyncorePlus 230 V
Temperature range heater cover	20 - 70 °C	20 - 70 °C	20 - 70 °C
Temperature range heater base	20 - 100 °C	20 - 100 °C	20 - 100 °C
Temperature accuracy at 100 °C	+/- 1 °C	+/- 1 °C	+/- 1 °C
Temperature accuracy at 120 °C (Service test)	+/- 2 °C	+/- 2 °C	+/- 2 °C
Fuse (100 / 115 V)	SPT 12.5	SPT 12.5	FST 10
Connections external valves (MiniDIN)	24 V ± 5 %	24 V ± 5 %	24 V ± 5 %
Connections communication (COM)	30 V ± 5 %	30 V ± 5 %	30 V ± 5 %
Overvoltage category	II	II	II
IP Code	IP 20	IP 20	IP 20
Pollution degree	2	2	2
Approvals	CE/CB	CE/CB	CE/CB

3.5.2 Ambient conditions

For indoor use only.

Max. altitude above sea level	2000 m
Ambient temperature	5–40 °C
Maximum relative humidity	80% for temperatures up to 31 °C decreasing linearly to 50 % relative humidity at 40 °C
Storage temperature	max. 45 °C

3.5.3 Materials

Component	Materials of construction
Main unit	St 1.4301
Protective shield	PMMA
Rack	Aluminum anodized
Vacuum connection	Aluminum with PFA coating
Glass in vacuum connection	Borosilicate glass
Vacuum hose	Ribbed PFA
Condenser	Borosilicate glass
Sealing discs Rack R4 and R-6	PTFE coating
Glass with residual volume appendix Glass R-4 and Glass R-6	Borosilicate glass
Sealing discs, Rack R-24, R48 and R-96	Polyethylene
Crush protection	POM

4 Transport and storage

4.1 Transport



NOTICE

Risk of breakage due to incorrect transportation

- ▶ Make sure that the instrument is fully dismantled.
 - ▶ Pack all instrument components properly to prevent breakage. Use the original packaging whenever possible.
 - ▶ Avoid sharp movements during transit.
-
- ▶ After transporting, check the instrument and all glass components for damage.
 - ▶ Damage that has occurred in transit should be reported to the carrier.
 - ▶ Keep packaging for future transportation.

4.2 Storage

- ▶ Make sure that the ambient conditions are complied with (see Chapter 3.5 “Technical data”, page 17).
- ▶ Wherever possible, store the instrument in its original packaging.
- ▶ After storage, check the instrument, all glass components, seals and tubing for damage and replace if necessary.

4.3 Lifting the instrument



NOTICE

Dragging the instrument can damage the feet of the instrument.

- ▶ Lift the instrument when positioning or re-locating.
-
- ▶ Lift the instrument at the points indicated ((1) + (3) and (2) + (3)).

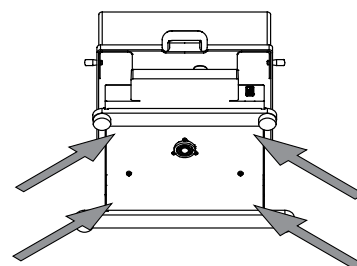

5 Installation

5.1 Before installation



NOTICE

Instrument damage due to switching it on too early.

Switching on the instrument too early after transportation can cause damage.

- ▶ Climatize the instrument after transportation.

5.2 Installation site



NOTE

Make sure that the power supply can be disconnected at any time in an emergency.

The installation site must meet the following requirements:

- Firm, level surface.
- Take into account the maximum product dimensions and weight. See Chapter 3.5 “Technical data”, page 17
- Take into account the weight of the set up and the samples.
- Do not place loose papers or cloths below or to the sides of the instrument, as these could impede the air circulation if drawn in.
- Do not place the instrument near vibration-sensitive devices.
- Make sure that cables / tubes can be routed safely.
- Own mains outlet socket

5.3 Establishing electrical connections



NOTICE

Risk of instrument damage because of not suitable power supply cables.

Not suitable power supply cables can cause bad performance or an instrument damage

- ▶ Use only BUCHI power supply cables.

Precondition:

- The electrical installation is as specified on the type plate.
- The electrical installation is equipped with a proper grounding system.
- The electrical installation is equipped with suitable fuses and electrical safety features.
- The installation site is as specified in the technical data. See Chapter 3.5 “Technical data”, page 17.

- ▶ Connect the power supply cable to the connection on the instrument. See Chapter 3.2 “Configuration”, page 14.
- ▶ Connect the mains plug to an own mains outlet socket.

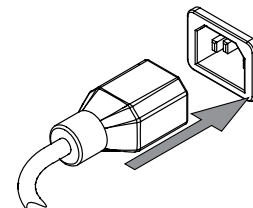

5.4 Securing against earthquakes



NOTE

- ▶ Eye screw M10 x 10.
- ▶ Screw-in depth 10 mm.



NOTE

Choose the tap hole according to your installation.

Position tap hole see Chapter 3.2 “Configuration”, page 14

- ▶ Attach the eye screws to the instrument.
- ▶ Attach the instrument to a fixed point using a strong cord or a wire.

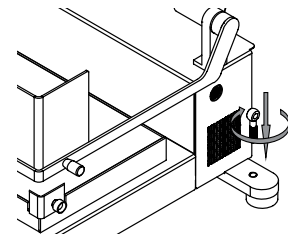

5.5 Connecting the instrument to the control system



NOTE

Using the control system. See operation manual *Interface I-300 Pro*.

5.6 Installing the condenser



NOTE

Choose the tap hole according to your installation.

Position tap hole see Chapter 3.2 “Configuration”, page 14

5.6.1 Installing the condenser

- ▶ Attach the support rod to the instrument.

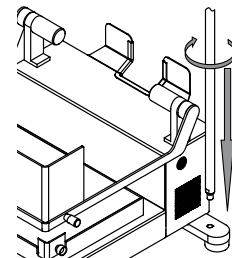

- ▶ Attach the cross sleeve to the support rod.

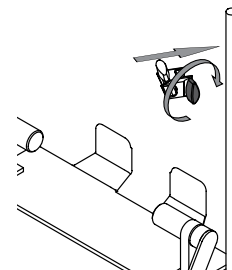

Use the marked area.

- ▶ Attach the support rod to the condenser.

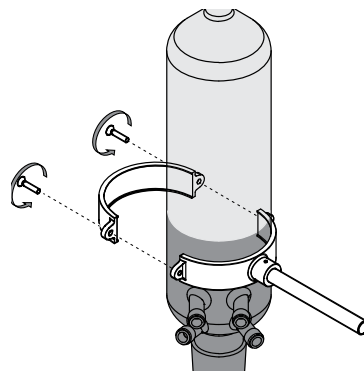

- ▶ Attach the condenser to the cross sleeve.

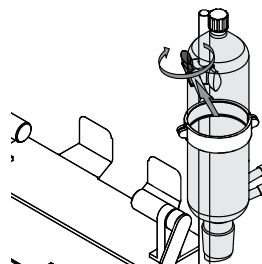

- ▶ Attach the vacuum adapter to the condenser with the clamp.

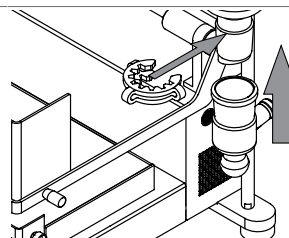

- ▶ Attach the receiving vessel to the vacuum adapter with a ball joint clamp.

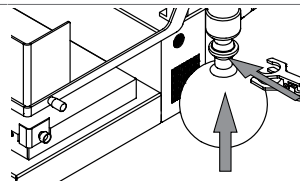

5.6.2 Connecting the coolant to the condenser

- ▶ Install the coolant hoses onto the hose nipples.
- ▶ Secure the coolant hoses in place with a hose clip.

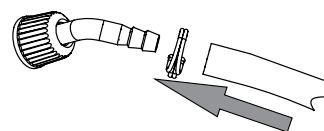

- ▶ Attach the prepared coolant hoses onto the condenser.

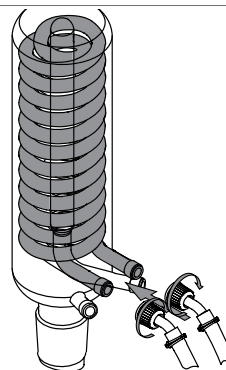

5.6.3 Connecting the vacuum pump to the condenser

- ▶ Install the vacuum hose onto the hose nipples.

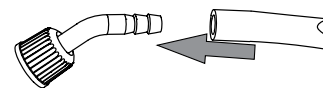

- ▶ Attach the prepared vacuum hose onto the condenser.

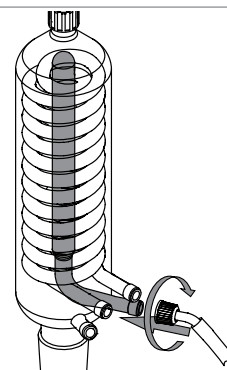

5.6.4 Connecting the vacuum hose for the heater cover

- ▶ Attach the vacuum hose from the heater cover to the vacuum adapter.

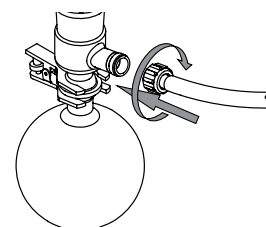

5.6.5 Installing the cap nut (Polyvap and Analyst configuration only)

- ▶ Attach the cap nut with seal onto the condenser.

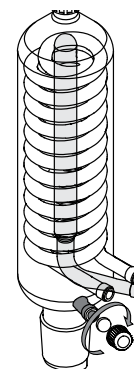

5.6.6 Installing the vapor sensor (Option)

There are two vapor sensors available:

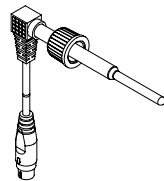
	Order no.	Image
Vapor temperature sensor. Incl. cap nut, seal GL14 Measures the vapor temperature inside the system. Meant to be used with the Interface I-300 Pro. Only for vapor temperature, can not be upgraded to AutoDest sensor.	11060707	

	Order no.	Image
AutoDest sensor. Incl. cap nut, seal GL14 and adapter cable for SyncorePlus For automatic distillation. Measures temperature of cooling media and the vapor temperature. Vacuum is adjusted according to cooling capacity of condenser. Meant to be used with the Interface I-300 Pro.	11081310	
Set AutoDest sensor & AutoDry valve & adapter cable for SyncorePlus Set includes AutoDest sensor 11059225, AutoDry valve 11074082 and adapter cable for SyncorePlus 11069477	11081315	
AutoDry valve In combination with AutoDest sensor for automated distillation of residual solvent. Meant to be used with AutoDest sensor 11059225, Adapter cable for SyncorePlus 11069477, Interface I-300 Pro and S-type condenser.	11074082	

- ▶ Attach the sensor to the condenser.

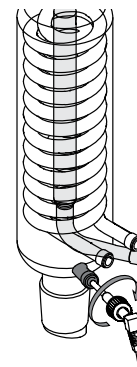

- ▶ Attach the plug onto the VacuBox.

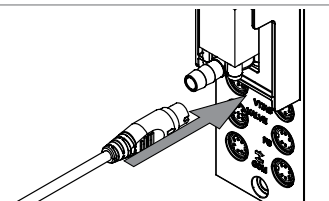

5.7 Installing the waste vessel (SPE configuration only)

- ▶ Assemble the waste bottle.

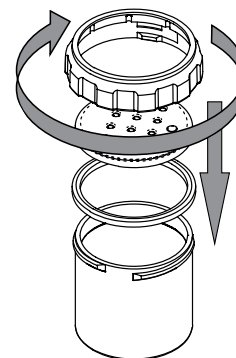

- ▶ Attach the support rod onto the waste bottle.

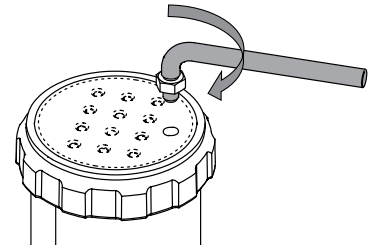

- ▶ Secure the support rod in place with the nut.

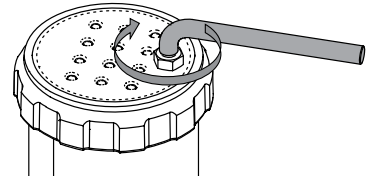

NOTICE! Push the hose 3 cm in the waste bottle

- ▶ Attach the waste line to the waste bottle.

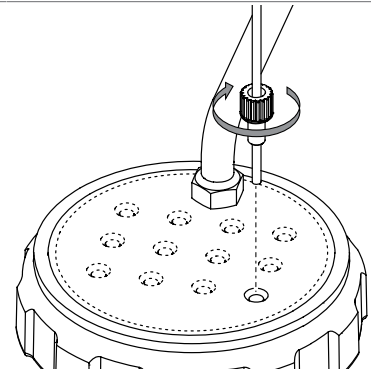

- ▶ Attach the cross sleeve to the support rod.

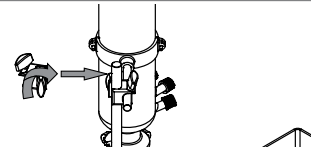

- ▶ Attach the waste vessel to the support rod.

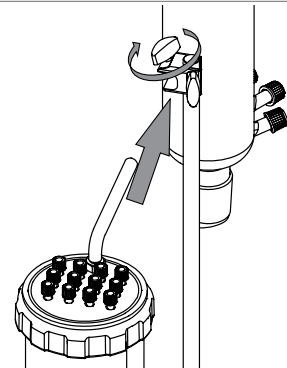

- ▶ Attach the waste tube onto the waste bottle.

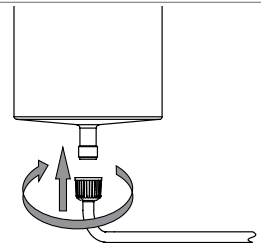

- ▶ Attach the waste tube onto the condenser.

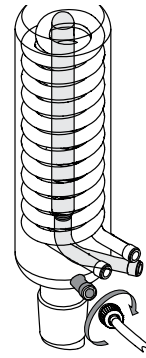

6 Preparing the instrument for a configuration

6.1 Preparing a Polyvap configuration

- ▶ Make sure that the surface of the heater base is clean.

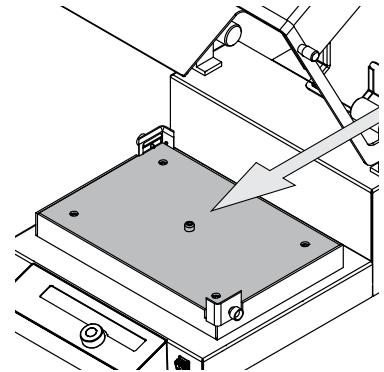

- ▶ Put the rack on the heater base.

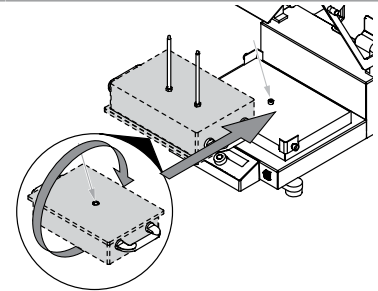

- ▶ Make sure that there are no spaces between rack and heater base.

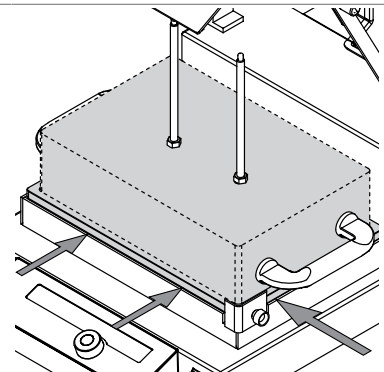

- ▶ Secure the rack in place with the screws on both sides.

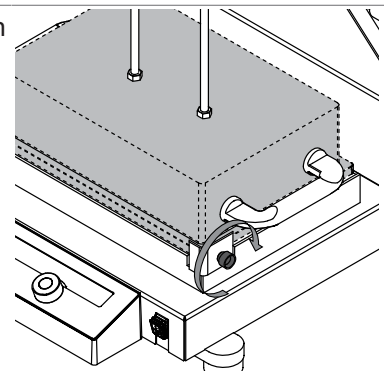

- ▶ Fill water into the rack.

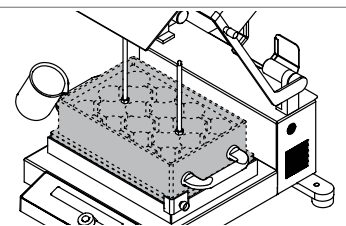

- ▶ Attach the vacuum hose to the heater cover.

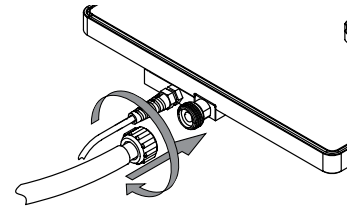

- ▶ Put the heater cover on the instrument.

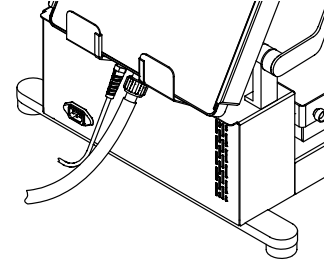

- ▶ Connect the heater cover to the instrument.

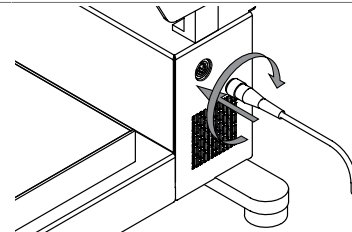

- ▶ If using a rack with 24 or more positions, place a spring in each hole.

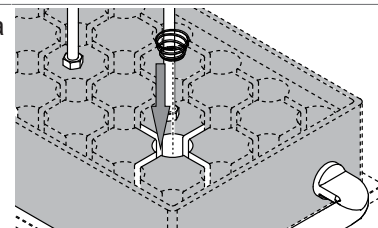

- ▶ Put the sample tubes in the rack.

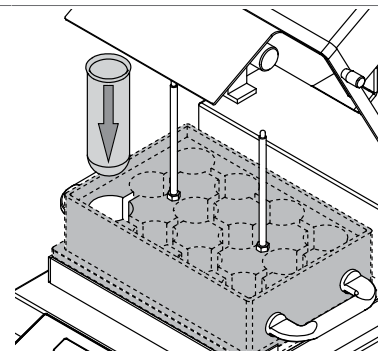

- ▶ Close the protective cover.

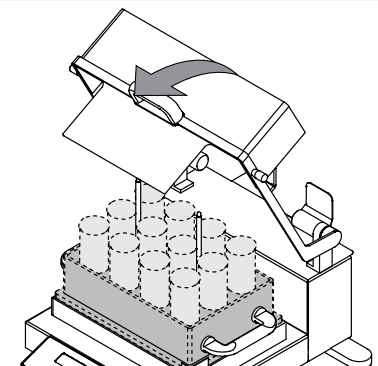

- ▶ Put the heater cover on the rack.

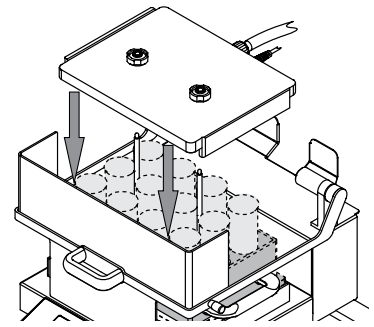

NOTICE! Do not tighten the knurl nuts too much.

- ▶ Tighten the knurl nuts with your hand.

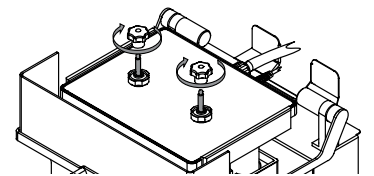

6.2 Preparing an Analyst configuration

- ▶ Make sure that the surface of the heater base is clean.

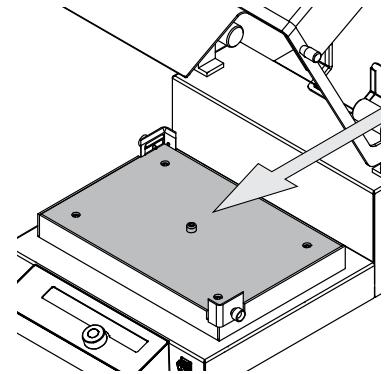

- ▶ Put the rack on the heater base.

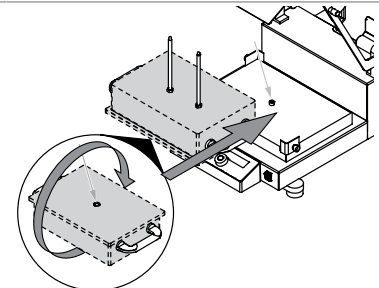

- ▶ Make sure that there are no spaces between rack and heater base.

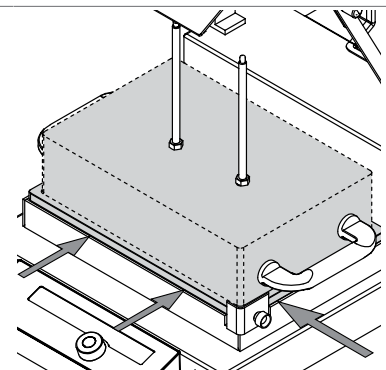

- ▶ Secure the rack in place with the screws on both sides.

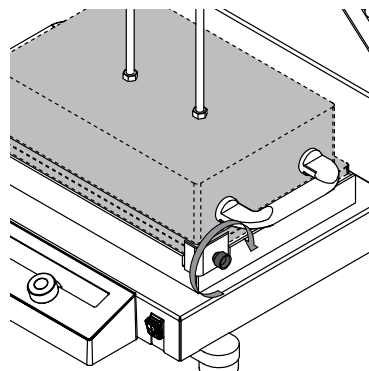

- ▶ Install the condenser tubes onto the rack.
- ▶ Attach the condenser tubes in place with a hose clip.

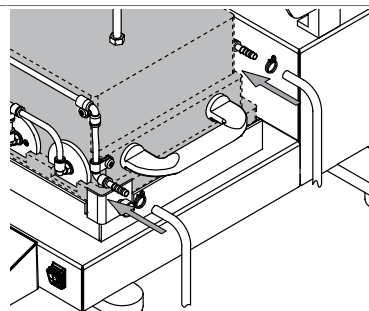

- ▶ If appendix is less than 3 mL insert sealing.

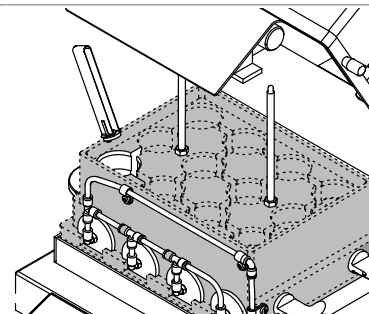

- ▶ Fill water into the rack.

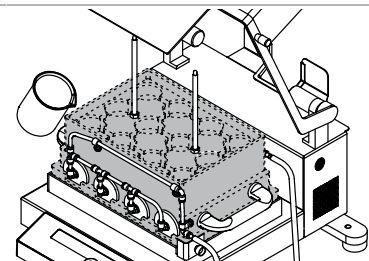

- ▶ Attach the vacuum hose to the heater cover.

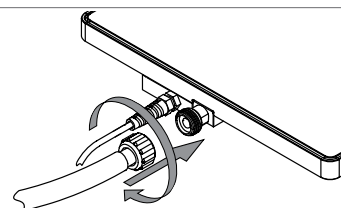

- ▶ Put the heater cover on the instrument.

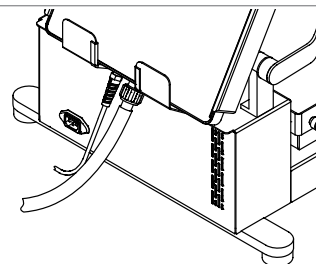

- ▶ Connect the heater cover to the instrument.

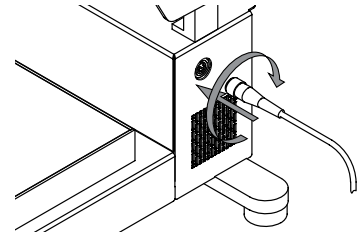

- ▶ Put the sample tubes in the rack.

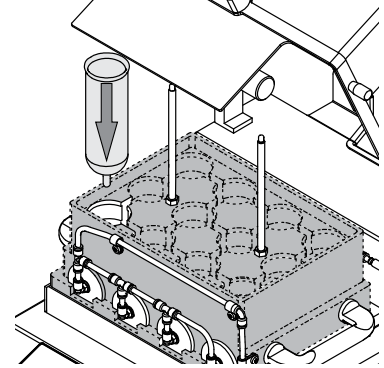

- ▶ Close the protective cover.

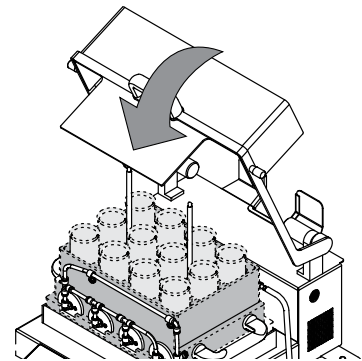

- ▶ Put the heater cover on the rack.

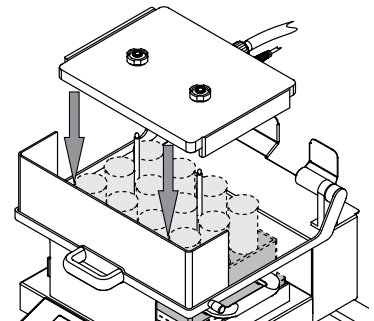

NOTICE! Do not tighten the knurl nuts too much.

- ▶ Tighten the knurl nuts with your hand.

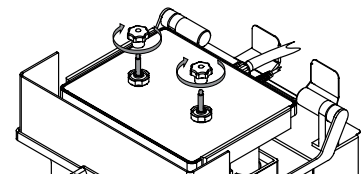

6.3 Preparing a SPE configuration

- ▶ Make sure that the surface of the heater base is clean.

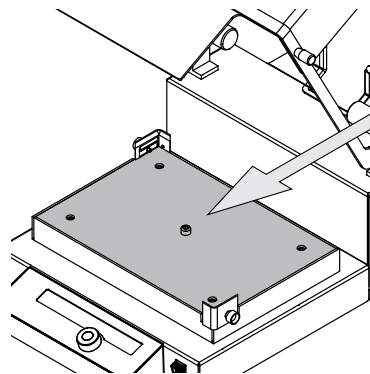

- ▶ Put the rack on the heater base.

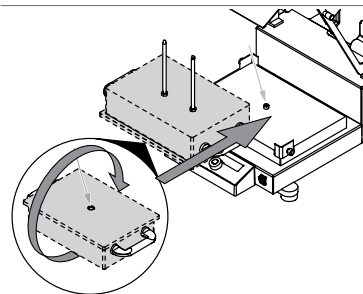

- ▶ Make sure that there are no spaces between rack and heater base.

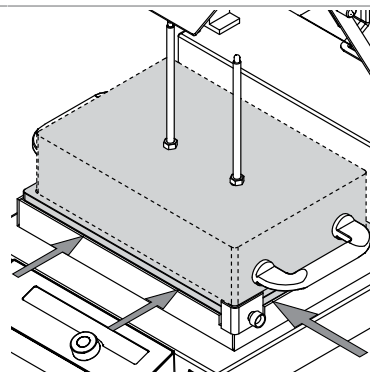

- ▶ Secure the rack in place with the screws on both sides.

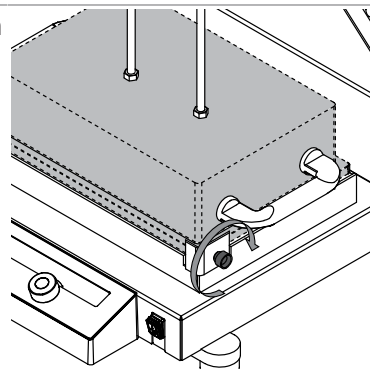

- ▶ Fill water into the rack.

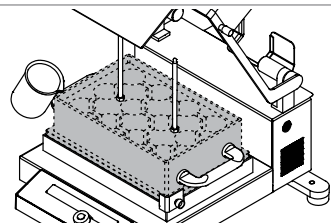

- ▶ Attach the vacuum hose to the heater cover.

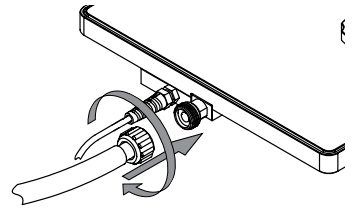

- ▶ Connect the heater cover to the instrument.

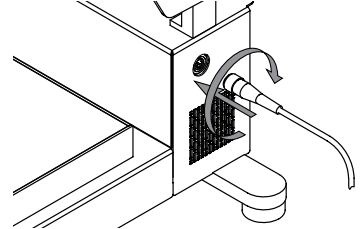

- ▶ Put the cover on the instrument.

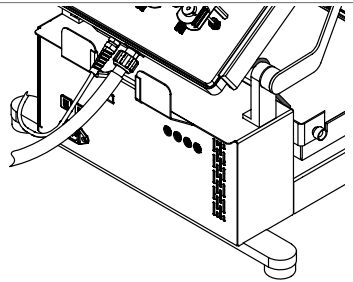

- ▶ Put the sample tubes in the rack.

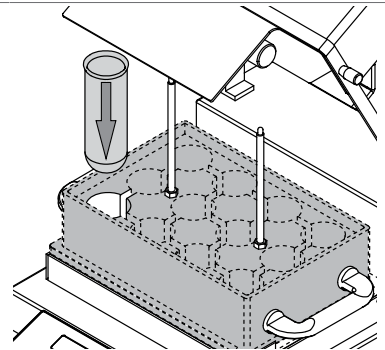

- ▶ Close the protective cover.

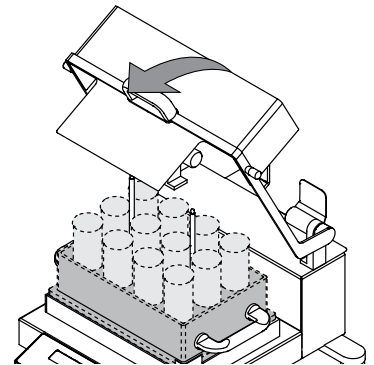

- ▶ Put the heater cover on the rack.

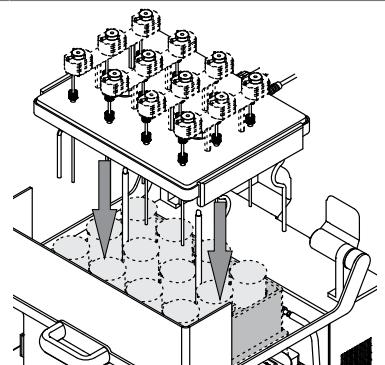

NOTICE! Do not tighten the knurl nuts too much.

- ▶ Tighten the knurl nuts with your hand.

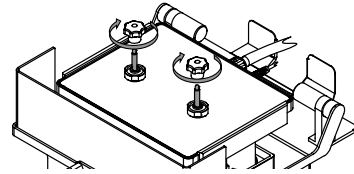

- ▶ Attach the waste line to the valve.

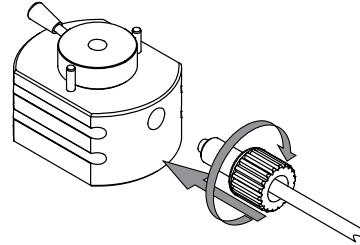

- ▶ Prepare the sample according to your needs.

6.3.1 Position SPE advanced valves

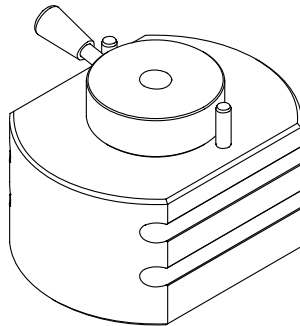

Elute
The sample flows in the tube

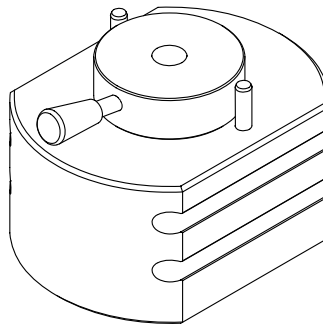

Stop

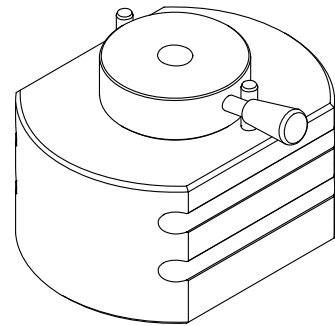

Waste
Sample flows in the waste

7 Operation

7.1 Operating the control panel

7.1.1 Layout of the control panel



⚠ CAUTION

Risk of injury from glass splinters

Sharp objects can damage the display.

- ▶ Keep sharp objects away from the display.

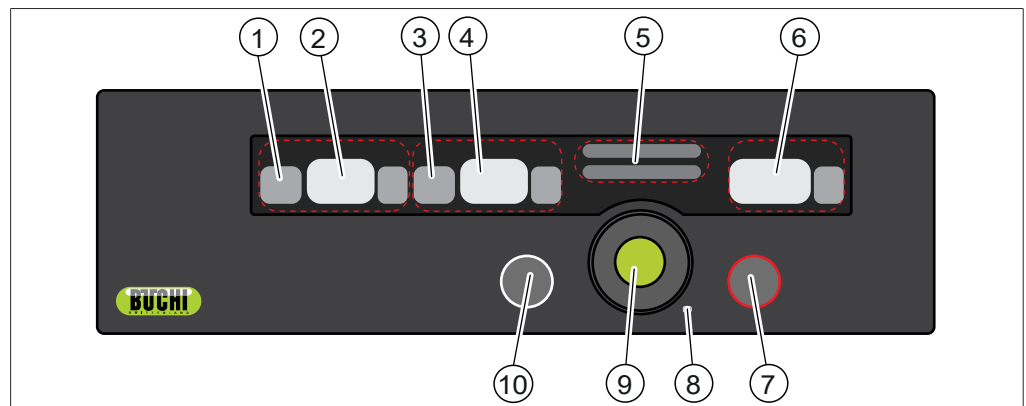





Fig. 8: Layout of the display

- | | |
|---|---|
| <p>1 According to the current operation:</p> <ul style="list-style-type: none"> • Set temperature heater cover • Offset temperature between heater cover and heater base <p>3 According to the current operation:</p> <ul style="list-style-type: none"> • Set temperature heater base <p>5 Status panel
See Chapter 7.1.2 “Status panel”, page 35</p> <p>7 Button STOP</p> <p>9 Navigation control</p> | <p>2 Actual temperature heater cover</p> <p>4 Actual temperature heater base</p> <p>6 According to the current operation:</p> <ul style="list-style-type: none"> • Rotation speed • Error code See Chapter 9.2 “Error messages”, page 42 <p>8 Icon Lock</p> <p>10 Button SET</p> |
|---|---|

7.1.2 Status panel

The status panel can display the following status:

View	Status
START	The instrument is ready to start
PAUSE	The instrument is carrying out an evaporation
OK	Confirm set values
CW	A cooling water valve is connected
	Cooling water valve activated
	Setting mode

View	Status
	Vacubox and Interface are connected
	Rotation is locked See Chapter 8.2 "Locking and unlocking the rotation", page 39

7.1.3 Setting the evaporation temperature

Offset temperature:

- The cover temperature is automatically adjusted with the heater base temperature.
- The range can be set between 20 - 70 °C



NOTE

After 1 minute without using the control panel the instrument returns to the basic mode.

- ▶ Tap the button **SET**.
 - ⇒ The set temperature for heater base flashes.
 - ⇒ The status panel shows the status **OK** and Setting.
- ▶ Turn the navigation control to the temperature according to the requirements.
- ▶ Tap the button **SET**.
- ▶ Turn the navigation control to the offset value according to the requirements.
- ▶ Tap the button **SET**.
 - ⇒ The offset temperature is changed.
 - ⇒ The temperature is set.

7.1.4 Setting the cooling water follow-up time



NOTE

After 1 minute without using the control panel the instrument returns to the basic mode.

The follow-up cooling water time can be set from 0 - 30 min.

- ▶ Tap the button **SET** three times (3x).
- ▶ Turn the navigation control to the follow-up time according to the requirements.
- ▶ Tap the button **SET**.
 - ⇒ The cooling water follow-up time is changed.

7.2 Carrying out an evaporation (with control system)



NOTE

Using the control system. See operation manual *Interface I-300 Pro*.

7.3 Carrying out an evaporation (without control system)



WARNING

Risk of explosion from excessive internal pressure

The evaporating flask and/or the condenser could explode if the internal pressure produced by evaporation becomes too great.

- ▶ Make sure that the pressure in the system is never greater than atmospheric pressure.



CAUTION

Risk of injury from solvent splashes and hot heating fluid splashes

- ▶ Use the protection shield.
- ▶ Make sure that protection against splashes in all directions is provided.
- ▶ When the evaporating flask is rotating look out for splashing fluid.

7.3.1 Preparing the instrument

Precondition:

- All commissioning operations have been completed. See Chapter 5 “Installation”, page 20
- ▶ Set the On/Off master switch to On.

7.3.2 Starting an evaporation



NOTE

To reduce processing time preheat the instrument.



NOTE

If you want to use rotation make sure that the status box does not show the status locked.

- ▶ Prepare the configuration. See Chapter 6 “Preparing the instrument for a configuration”, page 27
- ▶ Set the heating temperature. See Chapter 7.1.3 “Setting the evaporation temperature”, page 36
- ▶ Switch on the connected chiller or open the water tap.
- ▶ Press the navigation control.
 - ⇒ The instrument is heating.
 - ⇒ The status box shows the status Pause.
- ▶ Make sure that the cooling water temperature meets the requirements.
- ▶ Wait until the cover and base temperatures fit the set value.
- ▶ Switch on the vacuum.
- ▶ Turn the navigation control to the rotation speed according to the requirements.
 - ⇒ The instrument is rotating.

7.3.3 Ending an evaporation

- ▶ Tap the button **STOP**.
 - ⇒ The instrument stops heating.
 - ⇒ The instrument stops the rotation.
- ▶ Switch off the connected chiller or close the water tap.

7.3.4 Shutting down the instrument

- ▶ Set the On/Off master switch to Off.

8 Cleaning and servicing



NOTE

- ▶ Carry out only the service and cleaning operations described in this section.
- ▶ Do not carry out any servicing and cleaning operations that involve opening the housing.
- ▶ Use only genuine BUCHI spare parts in order to ensure correct operation and preserve the warranty.
- ▶ Carry out the service and cleaning operations described in this section to extend the lifetime of the instrument.

8.1 Regular maintenance work



⚠ CAUTION

Hot surfaces.

Skin burns from hot surfaces.

- ▶ Let the instrument cool down sufficiently before carrying out any maintenance work.



NOTE

It is the responsibility of the operators to select the correct cleaning agents and materials.

- ▶ Do not use abrasive cleaning material.
- ▶ Make sure that the cleaning agent meets the requirements of the safety data sheets for the chemicals used.
- ▶ Make sure that the cleaning agent is compatible with the materials used. See Chapter 3.5 “Technical data”, page 17
- ▶ If you have any further questions, contact BUCHI Customer Service.



NOTE

Lock the instrument before carrying out any regular maintenance work. See Chapter 8.2 “Locking and unlocking the rotation”, page 39

Component	Action	Frequency
Casing	<ul style="list-style-type: none"> ▶ Wipe down the casing with a damp cloth. ▶ If heavily soiled, use ethanol or a mild detergent. 	Weekly
Warning symbols	<ul style="list-style-type: none"> ▶ Check that the warning symbols on the instrument are legible. ▶ If they are dirty, clean them. 	Weekly
Rack mount	<ul style="list-style-type: none"> ▶ Wipe down the rack mount with a damp cloth. ▶ If heavily soiled, use ethanol or a mild detergent. 	Monthly
Base plate mount	<ul style="list-style-type: none"> ▶ Wipe down the base plate with a damp cloth. ▶ If heavily soiled, use ethanol or a mild detergent. 	Monthly

8.2 Locking and unlocking the rotation

Locking the rotation

- ▶ Press the navigation control 2 seconds.
 - ⇒ The rotation is locked.
 - ⇒ The status box shows the status locked.

Unlocking the rotation

Precondition:

- The status box shows the status locked.
- ▶ Press the navigation control 2 seconds.
 - ⇒ The rotation is unlocked.

8.3 Moving and retrieving the heating plate into a pre-defined position

For adjusting the unbalance compensation, the heating plate has to be in a pre-defined position.

Moving the heating plate into a pre-defined position

- ▶ Press the button **STOP** 5 seconds.
 - ⇒ The heating plate moves to a pre-defined position.
 - ⇒ The heating plate is locked.

Retrieving the heating plate from a pre-defined position

- ▶ Press the button **STOP**.
 - ⇒ The heating plate is unlocked.

8.4 Adjusting the unbalance compensation

The unbalance compensation is used to change the distance of a balancing weight from the horizontal axis of the vortex movement.

A sensor monitors the vibration and controls the rotation speed.



NOTE

The default setting of the unbalance compensation is 23 mm. This default setting covers all standardized operations.

- ▶ Move the heating plate to the pre-defined stopping position. See Chapter 8.3 “Moving and retrieving the heating plate into a pre-defined position”, page 39

- ▶ Insert the tool.

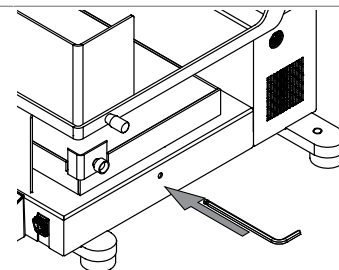

Use the scale marked on the tool.

- ▶ Turn the tool to adjust the unbalance compensation.
- Turn counterclockwise to reduce the eccentricity.
- Turn clockwise to increase the eccentricity.

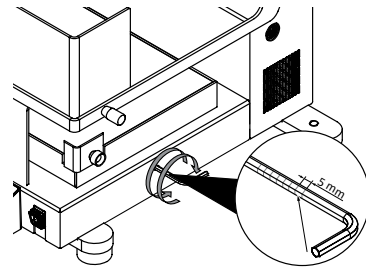

- ▶ Remove the tool.

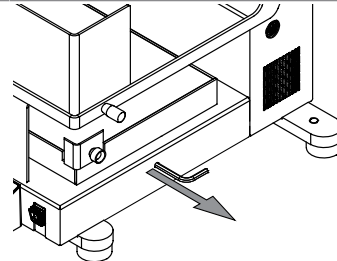

- ▶ Retrieve the heating plate from the pre-defined stopping position. See Chapter 8.3 “Moving and retrieving the heating plate into a pre-defined position”, page 39

8.5 Testing the vortex movement

- ▶ Prepare the configuration. See Chapter 6 “Preparing the instrument for a configuration”, page 27
- ▶ Turn the navigation control to the rotation speed according to the requirements.
- ▶ Make sure that the requested rotation speed is the same as the rotation speed shown on the display.

9 Help with faults

9.1 Troubleshooting

Problem	Possible cause	Action
The display is black	No power.	<ul style="list-style-type: none"> ▶ Establish an electrical connection. ▶ Check the fuse.
Display lights only in part	Display unit is defect.	▶ Contact BUCHI Customer Service.
Instrument does not heat up	Temperature is set too low.	▶ Raise the temperature.
	Heater is switched off.	▶ Switch on the heater.
	The heater is defect.	▶ Contact BUCHI Customer Service.
	Temperature sensor is defect.	▶ Contact BUCHI Customer Service.
Instrument does not rotate	The rotation speed is too low.	▶ Move the Navigation control clockwise.
	Automatic speed limit is active caused by an unbalance.	▶ Adjust the unbalance compensation. See Chapter 8.4 "Adjusting the unbalance compensation", page 39
	The drive belt is torn.	▶ Contact BUCHI Customer Service.
	The instrument is defect.	▶ Contact BUCHI Customer Service.
Heater cover is not heated	The cover is not connected.	▶ Connect the cover.
	The temperature is set too low.	▶ Raise the temperature.
	The heater is defect.	▶ Contact BUCHI Customer Service.
Buttons do not react	The buttons are defect.	▶ Contact BUCHI Customer Service.
Noise	The vibration elements are defect.	<ul style="list-style-type: none"> ▶ Check the vibration elements. ▶ Contact BUCHI Customer Service.
Vibration	The rotation speed is too high.	▶ Reduce rotation speed.
Protection shield does not keep the upper position	The fixing screw is loose.	▶ Tighten the fixing screw.

9.2 Error messages

Error message	Possible cause	Solution
945	Acceleration of instrument too high during 1 sec. (first level)	<ul style="list-style-type: none"> ▶ Speed will be reduced automatically. ▶ Adjust the unbalance compensation.
946	Looped signal from the valve was available at start but lost during run	<ul style="list-style-type: none"> ▶ Check connection of valve. ▶ Check the valve cable.
948	Heater cover missing	<ul style="list-style-type: none"> ▶ Check connection to heater cover.
949	Over temperature in housing. Board temperature > 70 °C during 5 sec.	<ul style="list-style-type: none"> ▶ Clean the venting slot.
950	Difference target speed to actual speed higher than 10 rpm during 6 sec.	<ul style="list-style-type: none"> ▶ Check rack load. ▶ Restart the instrument. ▶ Contact BUCHI Customer Service.
951	Main voltage during 5 sec. below 198 V (nominal 230 V), 94 V (nominal 115 V), 80 V (nominal 100 V)	<ul style="list-style-type: none"> ▶ Check main voltage.
952	Feedback signal from fan is missing	<ul style="list-style-type: none"> ▶ Check fan for pollution. ▶ Restart the instrument. ▶ Contact BUCHI Customer Service.
953	The rise of the heater base temperature during 15 sec. is higher than expected	<ul style="list-style-type: none"> ▶ Check rack. ▶ Check thermal connection to the heater.
975	The fault signal from the valve driver is still active after 5 resets of the driver	<ul style="list-style-type: none"> ▶ Restart the instrument. ▶ Contact BUCHI Customer Service.
976	Heater was switched on and no reaction on the temperature sensor detected after first 20 sec.	<ul style="list-style-type: none"> ▶ Restart the instrument. ▶ Contact BUCHI Customer Service.
977	Heater is switched off, temperature sensor visible, but (at least one) heater element is not present	<ul style="list-style-type: none"> ▶ Restart the instrument. ▶ Contact BUCHI Customer Service.
978	Motor is on, but no signal from light barrier during 6 sec.	<ul style="list-style-type: none"> ▶ Restart the instrument. ▶ Contact BUCHI Customer Service.
979	Voltage during 1000 ms below/above 30.0 V ±10%	<ul style="list-style-type: none"> ▶ Check power supply or instrument for overloading components like wrong external valves or short circuits.
980	Access to EEPROM not possible	<ul style="list-style-type: none"> ▶ Restart the instrument. ▶ Contact BUCHI Customer Service.

Error message	Possible cause	Solution
981	No I2C signal from touch controller during 300 ms	<ul style="list-style-type: none"> ▶ Restart the instrument. ▶ Contact BUCHI Customer Service.
982	No I2C signal from display during 300 ms	<ul style="list-style-type: none"> ▶ Restart the instrument. ▶ Contact BUCHI Customer Service.
983	The fault signal from the motor driver is still active after 5 resets of the driver	<ul style="list-style-type: none"> ▶ Restart the instrument. ▶ Contact BUCHI Customer Service.
984	No signal from motor encoder during 3 sec.	<ul style="list-style-type: none"> ▶ Restart the instrument. ▶ Contact BUCHI Customer Service.
985	No sensor connection bit from AD converter set during 1 sec.	<ul style="list-style-type: none"> ▶ Restart the instrument. ▶ Contact BUCHI Customer Service.
986	No sensor connection bit from AD converter set during 1 sec.	<ul style="list-style-type: none"> ▶ Restart the instrument. ▶ Contact BUCHI Customer Service.
987	Temperature of Cover for more than 3 sec. above 80 °C	<ul style="list-style-type: none"> ▶ Check Cover connection. ▶ Restart the instrument. ▶ Contact BUCHI Customer Service.
988	Temperature of Base for more than 3 sec. above 120°C	<ul style="list-style-type: none"> ▶ Replace the defective parts ▶ Restart the instrument. ▶ Contact BUCHI Customer Service.
989	Current of motor above 1.5 A during 3 sec.	<ul style="list-style-type: none"> ▶ Check drive for blocking elements. ▶ Check motor drive, and rack load.
990	Main voltage during 5 sec. above 275 V (nominal 230 V), 142 V (nominal 115 V), 120 V (nominal 100 V)	<ul style="list-style-type: none"> ▶ Check main voltage.
991	Acceleration of instrument above 0.126 g during 1 sec. (second level)	<ul style="list-style-type: none"> ▶ Adjust the unbalance compensation.
992	One or more parameter out of range	<ul style="list-style-type: none"> ▶ Check and reconfigure parameters. ▶ Restart the instrument. ▶ Contact BUCHI Customer Service.

9.3 Changing the fuse



WARNING

Risk of electric shock with connected power supply cable.

Serious injuries or death can result.

- ▶ Switch off the device.
 - ▶ Disconnect the power supply cable from the device.
-
- ▶ Set the On/Off master switch to Off.
 - ▶ Disconnect the power supply cable from the device.
 - ▶ Unscrew the fuse carrier (2).
 - ⇒ Make sure the O-ring on the fuse carrier is not damaged.
 - ▶ Replace the defective fuse (1).
 - ▶ Screw in the fuse carrier.
 - ▶ Connect the power supply cable.

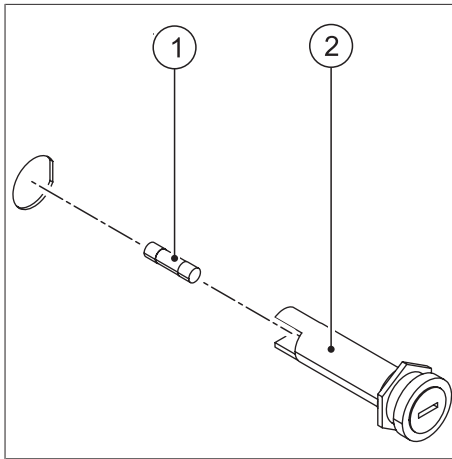

- ▶ If the fuse brakes repeatedly contact the Contact BUCHI Customer Service.

10 Taking out of service and disposal

10.1 Taking out of service

- ▶ Remove all solvents and coolants.
- ▶ Switch off the instrument and disconnect it from the mains power supply.
- ▶ Clean the instrument.
- ▶ Remove all tubing and communication cables from the device.

10.2 Disposal

The operator is responsible for proper disposal of the instrument.

- ▶ When disposing the equipment observe the local regulations and statutory requirements regarding waste disposal.
- ▶ When disposing, observe the disposal regulations of the materials used. For the used materials see Chapter 3.5 “Technical data”, page 17 or the material labeling on the parts.

10.3 Returning the instrument

Before returning the instrument, contact the BÜCHI Labortechnik AG Service Department.

<https://www.buchi.com/contact>

11 Appendix

11.1 Schematics

11.1.1 Cooling

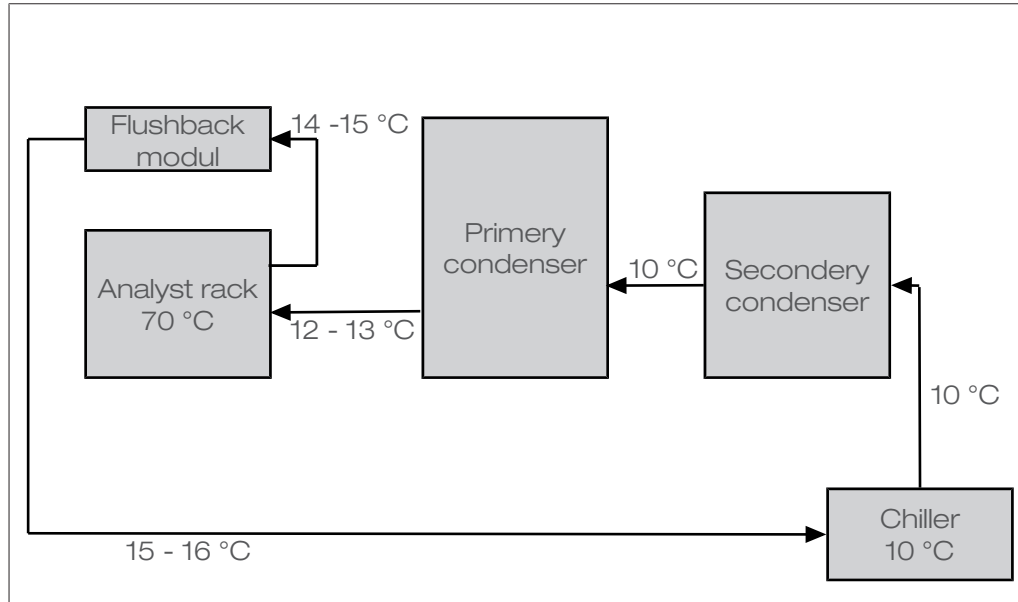

11.1.2 Communication connections

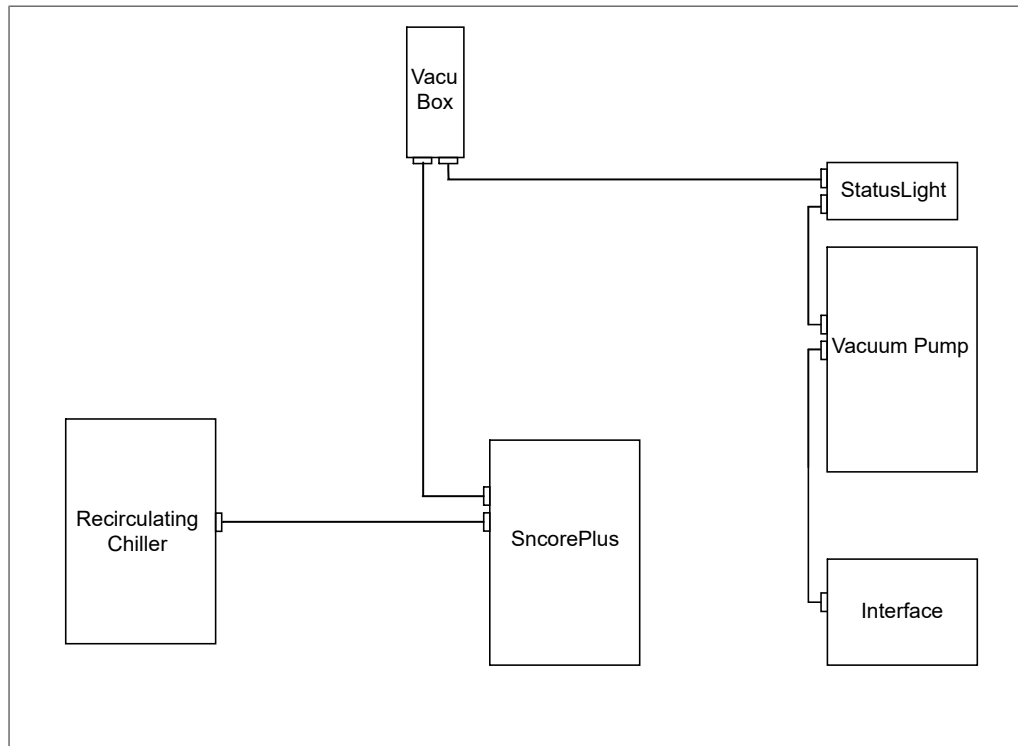

11.2 Spare parts and accessories

Use only genuine BUCHI consumables and spare parts in order to ensure correct, safe and reliable operation of the system.



NOTE

Any modifications of spare parts or assemblies are only allowed with the prior written permission of BUCHI.

11.2.1 Racks

Analyst racks

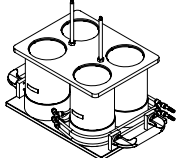
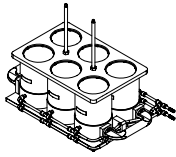
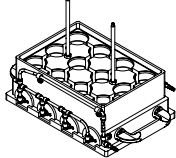
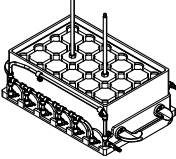
	Order no.	Image
Crystal Rack R-4 Analyst with residual volume cooling For a maximum working volume of up to 4 x 500 mL, without glass tubes	047794	
Crystal Rack R-6 Analyst with residual volume cooling For a maximum working volume of up to 6 x 250 mL, without glass tubes	047777	
EasyFill Rack R-12 Analyst with residual volume cooling For a maximum working volume of up to 12 x 120 mL, without glass tubes	046000	
EasyFill Rack R-24 Analyst with residual volume cooling For a maximum working volume of up to 24 x 25 mL, without glass tubes	11079940	

Polyvap racks

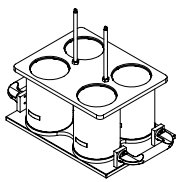
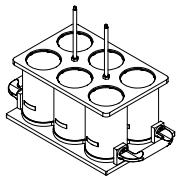
	Order no.	Image
Crystal Rack R-4 Polyvap For working volumes of up to 4 x 500 mL	047790	
Crystal Rack R-6 Polyvap For working volumes of up to 6 x 250 mL	047770	

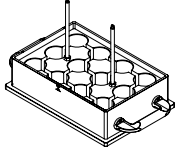
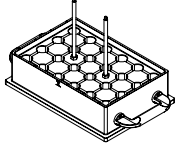
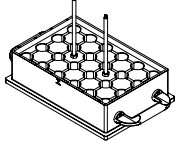
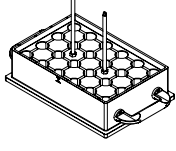
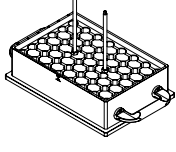
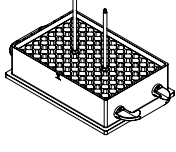
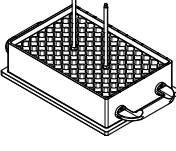
	Order no.	Image
<p>EasyFill Rack R-12 Polyvap</p> <p>For working volumes of up to 12 x 120 mL, without glass tubes</p>	040900	
<p>EasyFill Rack R-24 Polyvap with OD = 25 mm</p> <p>For working volumes of up to 24 x 30 mL, without glass tubes</p>	038188	
<p>EasyFill Rack R-24 Polyvap falcon Tubes</p> <p>For working volume of up to 24 x 30 mL, without falcon tubes</p>	038440	
<p>EasyFill Rack R-24 Polyvap PSE/ASE vials with OD = 27 mm</p> <p>For working volumes of up to 24 x 30 mL, without glass tubes</p>	042660	
<p>Easy Fill Rack R-48 Polyvap with OD = 20 mm</p> <p>For working volumes of up to 48 x 20 mL</p>	042855	
<p>EasyFill Rack R-96 Polyvap with OD = 16 mm</p> <p>For working volumes of up to 96 x 10 mL, without glass tubes</p>	038277	
<p>EasyFill Rack R-96 Polyvap with OD = 18 mm.</p> <p>For Working volumes up to 96 x 10 mL, without glass tubes.</p>	11072529	

Transportation rack

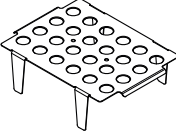

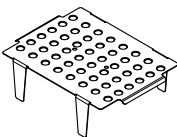
	Order no.	Image
<p>Transportationrack R-24 for 50 mL Falcon tubes</p> <p>Transport rack for easy preparation and insertion into the polyvap rack</p>	11074727	

	Order no.	Image
Transportationrack R-48 for 15 mL Falcon tubes Transport rack for easy preparation and insertion into the polyvap rack	11074075	

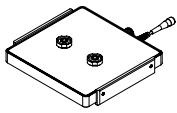
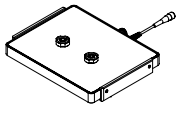
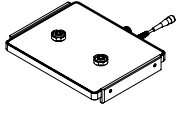
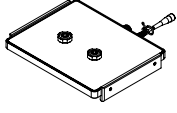
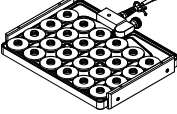
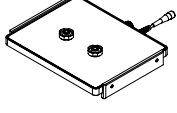
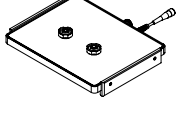
11.2.2 Cover

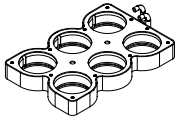

	Order no.	Image
Vacuum Cover R-4 with PTFE sealing disks Actively heated vacuum cover with individual sample connection	038245	
Vacuum Cover R-6 with PTFE sealing disks Actively heated vacuum cover with individual sample connection	038246	
Vacuum Cover R-12 with PTFE sealing disks Actively heated vacuum cover with individual sample connection	040910	
Vacuum Cover R-24 with PE sealing disks Actively heated vacuum cover with individual sample connection	040920	
Vacuum cover R-24 with PTFE sealing disks Actively heated vacuum cover with individual sample connection	11081339	
Vacuum Cover R-48 with PE sealing disks Actively heated vacuum cover with individual sample connection	042850	
Vacuum Cover R-96 with PE sealing disks Actively heated vacuum cover with individual sample connection	040930	



11.2.3 Flushback Module

	Order no.	Image
Flushback Module R-6 For higher recovery rates in combination with Crystal rack R-6 Analyst	048654	
Flushback Module R-12 For higher recovery rates in combination with EasyFill rack R-12 Analyst	046036	

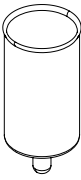
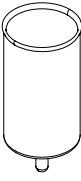
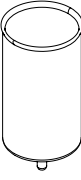

11.2.4 Tubes

Analyst tubes

	Order no.	Image
Set of 4 graduated glass tubes for Crystal rack R-4 Analyst, residual volume 3.0 mL Working volume up to 500 mL	047740	
Set of 4 graduated glass tubes for Crystal rack R-4 Analyst, residual volume 1.0 mL Working volume up to 500 mL	047741	
Set of 4 graduated glass tubes for Crystal rack R-4 Analyst, residual volume 0.3 mL Working volume up to 500 mL	047742	
Set of 6 graduated glass tubes for Crystal rack R-6 Analyst, residual volume 3.0 mL Working volume up to 250 mL	038557	
Set of 6 graduated glass tubes for Crystal rack R-6 Analyst, residual volume 1.0 mL Working volume up to 250 mL	038575	
Set of 6 graduated glass tubes for Crystal rack R-6 Analyst, residual volume 0.3 mL Working volume up to 250 mL	038168	
Set of 12 graduated glass tubes for EasyFill rack R-12 Analyst, residual volume 3.0 mL Working volume up to 120 mL	046070	

	Order no.	Image
Set of 12 graduated glass tubes for EasyFill rack R-12 Analyst, residual volume 1.0 mL Working volume up to 120 mL	046071	
Set of 12 graduated glass tubes for EasyFill rack R-12 Analyst, residual volume 0.3 mL Working volume up to 120 mL	046072	
Set of 24 graduated glass tubes for Easyfill rack R-24 Analyst, residual volume 1.0 mL Working volume up to 25 mL	11079938	
Set of 24 graduated glass tubes for Easyfill rack R-24 Analyst, residual volume 0.3 mL Working volume up to 25 mL	11079937	

GL45 thread tubes

	Order no.	Image
Set of 12 graduated glass tubes GL45 for EasyFill rack R-12 Analyst, residual volume 1.0 mL Working volume up to 100 mL	11056498	
Set of 12 graduated glass tubes GL45 for EasyFill rack R-12 Analyst, residual volume 0.3 mL Working volume up to 100 mL	11056499	

GL45 thread amber tubes

	Order no.	Image
Set of 12 graduated amber glass tubes GL45 for EasyFill rack R-12 Analyst, residual volume 1.0 mL Working volume up to 100 mL	11056910	
Set of 12 graduated amber glass tubes GL45 for EasyFill rack R-12 Analyst, residual volume 0.3 mL Working volume up to 100 mL	11056911	

Polyvap tubes

	Order no.	Image
Set of 4 glass tubes for Crystal Rack R-4 Polyvap Working volume up to 500 mL	038487	
Set of 6 glass tubes for Crystal Rack R-6 Polyvap Working volume up to 250 mL	038486	
Set of 12 glass tubes for EasyFill Rack R-12 Polyvap Working volume up to 120 mL	040907	
Set of 50 glass tubes for EasyFill Rack R-24 Polyvap Total volume 55 mL, 25 x 150 mm (d x h)	038469	
Set of 72 glass tubes for EasyFill Rack R-24 PSE/ASE Total volume 60 mL, 27 x 135 mm (d x h)	049535	
Set of 100 standard test tubes for EasyFill Rack R-48 Total volume 34 mL, 20 x 150 mm (d x h)	042845	
Set of 100 standard test tubes for EasyFill Rack R-96 Total volume 17 mL, 16 x 130 mm (d x h), for OD = 16 mm	038543	

11.2.5 Gaskets and plugs

	Order no.	Image
Set of 6 sealing disks for Vacuum Cover R-4 or R-6, PTFE	038488	
Set of 12 sealing disks for Vacuum Cover R-12, PTFE	040906	
Set of 24 sealing disks for Vacuum Cover R-24, PTFE	11081340	
Set of 24 sealing disks for Vacuum Cover R-24, PE	038489	

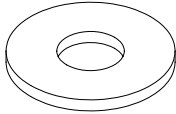
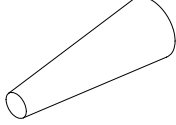
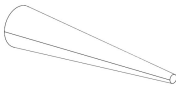
	Order no.	Image
Set of 50 sealing disks for Vacuum Cover R-48, PE	046591	
Set of 100 sealing disks for Vacuum Cover R-96, PE	038490	
Set rubber plugs 5 mm 6 pcs. For R-6 Cover	038542	
Set rubber plugs 3 mm 25 pcs. For R-12 and R-24 Cover	038704	
Rubber plug 1.1 mm 50 pcs. For R-48, R-64 and R-96 Cover	040193	

11.2.6 Sample preparation rack

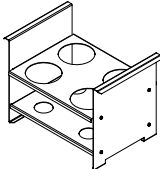
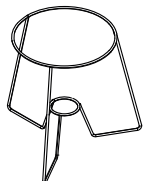
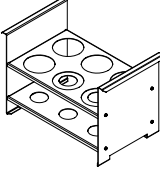
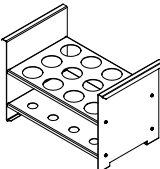
	Order no.	Image
Sample preparation rack R-4 (metal rack 4 positions)	040075	
Sample holder R-4 (metal rack 1 position)	11062988	
Sample preparation rack R-6 (metal rack 6 positions)	040076	
Sample holder R-6 (metal rack 1 position)	11062989	
Sample preparation rack R-12 (metal rack 12 positions)	040077	

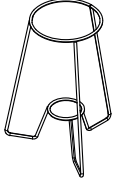
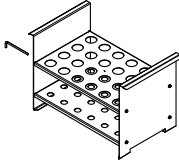
	Order no.	Image
Sample holder R-12 (metal rack 1 position)	11062990	
Sample preparation rack R-24 (metal rack 24 position)	11080763	

11.2.7 Condenser

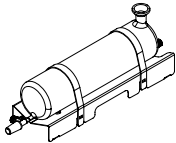
	Order no.	Image
Condenser unit type S, cpl. Including a 2000 mL receiving flask	11070721	
Refrigerated receiving flask 3000 mL with internal cooling loop, open	11061399	

11.2.8 Receiving flask

	Order no.	Image
Receiving flask Glass, BJ 35/20, 1000 mL, P+G	020728	
Glass, BJ35/20, 2000 mL, P+G	025265	

11.2.9 Cocking lever

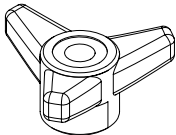
	Order no.	Image
3-star knob for the vacuum cover	11071146	
Set of 2 quick handle, star-shaped	11070467	

11.2.10 Sleeves

	Order no.	Image
Set of 12 appendix sleeves for Analyst glass tubes (R-4, R-6, R-12) with 0.3 mL appendix	11058511	
Set of 12 appendix sleeves for Analyst glass tubes with 1.0 mL appendix	11058510	

	Order no.	Image
Set of 24 appendix sleeves for Analyst glass tubes R-24 with 0.3 mL appendix	11081343	
Set of 12 appendix sleeves for Analyst glass tubes R-24 with 1.0 mL appendix	11081342	

11.2.11 Accessories SPE configuration

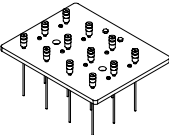
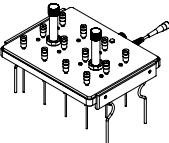
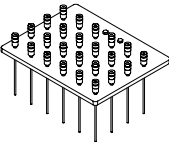
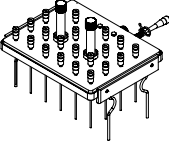
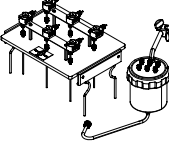
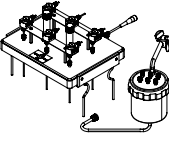
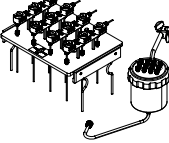
	Order no.	Image
SPE Basic Module format 12 with 2 way valve	051440	
SPE Basic Cover format 12 with 2 way valve	051438	
SPE Basic Module format 24 with 2 way valve	051463	
SPE Basic Cover format 24 with 2 way valve	051439	
SPE Advanced Module format 6 with 3 way valve and waste vessel	11055465	
SPE Advanced Cover format 6 with 3 way valve and waste vessel	11055466	
SPE Advanced Module format 12 with 3 way valve and waste vessel	051164	

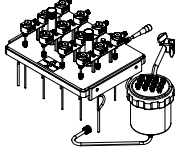
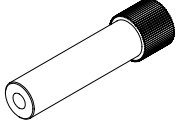
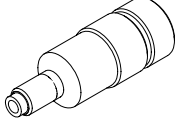
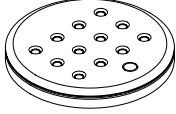
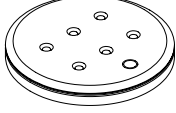
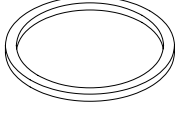
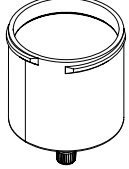
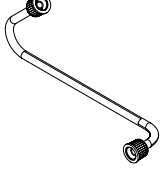
	Order no.	Image
SPE Advanced Cover format 12 with 3 way valve and waste vessel	051448	
Set of 2 SPE lock nuts	051464	
Flow-control valve, single	051129	
Set 12 O-rings for set 12 Flow-control valve	051453	
Set comprising of 6 flanged FEP tubes	051459	
Set of 12 FKM O-rings	051496	
12 port waste manifold	051445	
6 port waste manifold	11055463	
Gasket FPM to waste vessel	040471	
Glass cylinder for the SPE waste vessel	051444	
FEP tube waste condenser including GL 14 caps and seals	11064040	

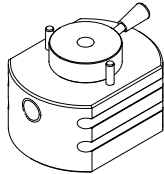
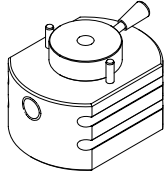
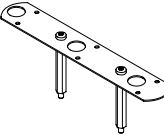
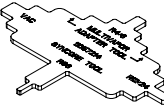
	Order no.	Image
Three-way stopcock	051163	
Set comprising of 12 SPE three-way stopcocks	051457	
Set of 4 FEP tube clips For bundle the hoses	051458	
Set of 12 FEP elution tubes Use between 3 way tap and waste vessel	051492	
Support for the three-way stopcocks	051493	
Set fittings 3.2 mm (25 pcs.) Use for attaching the hoses to the 3-way tap and the waste vessel	040956	
Set ferrules 3.2 mm (green, 25 pcs.) Use with 04956 for attaching the hoses to the 3-way tap and the waste vessel	040961	
Syncore / SyncorPlus tool	11057214	

11.2.12 Sensors

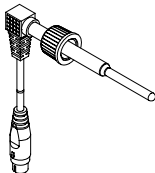
	Order no.	Image
Vapor temperature sensor. Incl. cap nut, seal GL14 Measures the vapor temperature inside the system. Meant to be used with the Interface I-300 Pro. Only for vapor temperature, can not be upgraded to AutoDest sensor.	11060707	
AutoDest sensor. Incl. cap nut, seal GL14 and adapter cable for SyncorePlus For automatic distillation. Measures temperature of cooling media and the vapor temperature. Vacuum is adjusted according to cooling capacity of condenser. Meant to be used with the Interface I-300 Pro.	11081310	

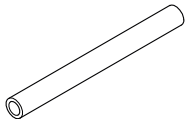
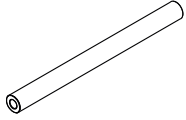
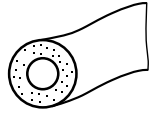

	Order no.	Image
AutoDry valve In combination with AutoDest sensor for automated distillation of residual solvent. Meant to be used with AutoDest sensor 11059225, Adapter cable for SyncorePlus 11069477, Interface I-300 Pro and S-type condenser.	11074082	
Set AutoDest sensor & AutoDry valve & adapter cable for SyncorePlus Set includes AutoDest sensor 11059225, AutoDry valve 11074082 and adapter cable for SyncorePlus 11069477	11081315	

11.2.13 Tubing

	Order no.	Image
Ribbed PFA vacuum hose, 600 mm Spiral vacuum tube (600 mm) with SVL22 connectors	049634	
Set of 2 PTFE sealings SVL22 Set consisting of 2 PTFE sealing rings (SVL22) for the vacuum hose (049634)	048899	
Tubing, silicone, Ø6/9 mm, transparent, per m Use: Cooling media	004133	
Tubing, synthetic rubber, Ø6/13 mm, black, per m Use: Vacuum	11063244	
Hose insulation, Kaiflex, 11/23, 1 m, black Use: cooling media, hose insulation	028696	

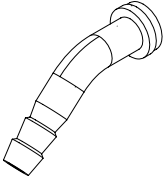
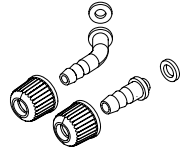
11.2.14 Hose barbs

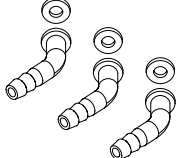
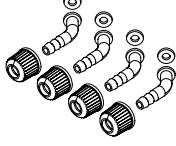
	Order no.	Image
Hose barb, bent, GL 14, incl. silicone seal	018916	
Hose barbs, set. 2 pcs, bent (1), straight (1), GL 14, silicone seal Content: Hose barbs, cap nuts, seals	041939	

	Order no.	Image
Hose barbs, set. 3 pcs, bent, GL 14, silicone seal Content: Hose barbs, seals.	041987	
Hose barbs, set. 4 pcs, bent GL 14, silicone seal Content: Hose barbs, cap nuts, seals	037287	
Hose barbs, set. 4 pcs, straight, GL 14, silicone seal Content: Hose barbs, cap nuts, seals	037642	
Hose barbs, set. 6 pcs, bent (4), straight (2), GL 14, silicone seal Content: Hose barbs, cap nuts, seals.	038000	

11.2.15 Tools

	Order no.	Image
Hose cutter	019830	
Turix wrench	044349	

11.2.16 Service

	Order no.	Image
SyncorePlus IQ/OQ documentation for first installation and operation qualification	11071011	
SyncorePlus Repeating OQ	11071012	



11594118 | D en

We are represented by more than 100 distribution partners worldwide.
Find your local representative at:

www.buchi.com

Quality in your hands
